



***Thermostat Control***  
*outside air solutions*

**O/M manual**

## Table of Contents

PART NUMBER AND DESCRIPTIONS.....	3-5
START UP REQUIREMENTS.....	6
REFRIGERANT PIPING GUIDELINES .....	7
CONTROLS, SAFETY AND START-UP DESCRIPTION.....	8-9
TROUBLESHOOTING AND SEQUENCE OF OPERATIONS.....	10
VICONICS THERMOSTAT NAVIGATION.....	11-17
BACNET POINTS .....	18
RESIDENTIAL TROUBLESHOOTING.....	19-35
INSTALLER NOTES.....	37-38

## SEE IOM-0035 O/M APPENDICES MANUAL FOR MORE INFORMATION ON INSTALLATION AND SET UP OF PERIPHERAL DEVICES

Reference IOM-0006 for more information on Economizer & Powered Exhaust

Reference IOM-0008 For more information on Air Flow Hood

Reference IOM-0011 For more information on Mod Gas Heat

Reference IOM-0012 For more information on Mod Electric Heat

Reference IOM-0015 For more information on Extra High Static Fan

Reference IOM-0018 For more information on Super High Heat Box

Reference IOM-0025 For more information on Mated ERV

Reference IOM-0053 For more information on Solar HVAC

\*\*\* ALL REFERENCE IOM'S AVAILABLE UPON REQUEST \*\*\*

### Contact iAIRE At:

[www.myiaire.com](http://www.myiaire.com)

Email: [sales@myiaire.com](mailto:sales@myiaire.com)

Phone: 844-348-9168



# ultraDRY Part Numbering Scheme

Commercial Package / Splits

## Type (1,2)

UD - Cooling Only  
 UG - with Gas Heat  
 UH - DX Cool w/H.W. Coils  
 UP - with Heat Pump  
 UW - WSHP

## Fan (4)

L - Low/Std. Static  
 M - Med. Static  
 H - High Static  
 E - Extra High Static

## Voltage (5)

G - 230 VAC 1 $\phi$   
 H - 230VAC 3 $\phi$   
 K - 460VAC 3 $\phi$   
 L - 575VAC 3 $\phi$

## Control (6)

0 - No Controls  
 A - DAT w/ VAV Duct  
 B - DAT w/ VAV Bldg  
 C - Thermostat w/ VAV Duct  
 D - DAT Control  
 E - Process w/ VAV Duct  
 F - Process w/ VAV Bldg  
 H - Thermostat w/ VAV Bldg  
 P - Process Control  
 S - Space (ERV only)  
 T - Thermostat Control  
 U - Space w/ VAV Duct (ERV only)  
 V - Space w/ VAV Bldg (ERV only)

## Electric & Gas Heat (7,8,9)

XXX - Electric (kW)  
 XXX - Gas (mBH)

## Heat Stages (10)

A - No Controls  
 B - 1 Stage  
 C - 2 Stage  
 D - 3 Stage  
 E - 4 Stage  
 M - Modulating

## Roof Top Units (3)

A30	FE04	HQP72	VQP72
A35	FE05	HQP96	VQP96
A40	FE06	HQP120	VQP120
A50	FE07	HQP150	VQP151
A60	FE08	HQP180	VQP181
FC04	FE09	HQP242	VQP210
FC05	FE12	K30	VQP240
FC06	FE14	K35	VQP300
FC07	FE16	K40	VQP360
FC08	FE20	K50	
FC09	FE24	K60	
FC12	FE28	V70	
FC14	FE30	V74	
FC16	GC04	V90	
FC20	GC05	V100	
FC24	GC06		
FC28	GE04		
FC30	GE05		
	GE06		

## Disconnect (11,12)

00 - No Disconnect  
 01 - 240V - 30A Fuse  
 02 - 240V - 60A Fuse  
 03 - 240V - 100A Fuse  
 04 - 240V - 150A Fuse  
 05 - 240V - 200A Fuse  
 06 - 240V - 300A Fuse  
 11 - 240V - 30A Switch  
 12 - 240V - 60A Switch  
 13 - 240V - 100A Switch  
 14 - 240V - 150A Switch  
 15 - 240V - 200A Switch  
 16 - 240V - 300A Switch  
 21 - 600V - 30A Fuse  
 22 - 600V - 60A Fuse  
 23 - 600V - 100A Fuse  
 24 - 600V - 150A Fuse  
 31 - 600V - 30A Switch  
 32 - 600V - 60A Switch  
 33 - 600V - 100A Switch  
 34 - 600V - 150A Switch

## Comm. Split (3)

COOLING	COOLING	HEAT PUMP
AZ07RF07*	AP25RA30**	AQ07RFQ07*
AZ08RF08*	AP27RA30**	AQ08RFQ08*
AZ12RF12*	AP30RA30**	AQ12RFQ12*
AZ14RF14*	AP4039M**	AQ16RFQ16**
AD12RF12**	AP5039M**	AQ25RQ25**
AD14RF14**	AP6039M**	
AD16RF16**	AP6539M*	
AD25RA25**	AP7039M**	
AD28RA28**	AP8039M**	
	AP9039M**	
	AP10039M**	

\*one circuit  
 \*\*two circuit

## Res. Split (3)

COOLING	HEAT PUMP
Z24FT3	Z24FT3
Z36FT3	Z36FT3
Z48FT6	Z48FT6
Z60FT6	Z60FT6
Z24Z36	Z24Z36
Z36Z36	Z36Z36
Z48Z60	Z48Z60
Z60Z60	Z60Z60

## Options (14)

0 - No Options  
 A - Ionization  
 B - Whole Unit (UG)  
 C - All Coils (UG)  
 D - Condenser Coil (UG)  
 E - ERV (See options pg.2)  
 F - MERV 13 2" Filter  
 G - 2 Pos. OA Damper  
 H - BACNet  
 J - Hinged Access Doors  
 K - DW w/ Poly Insulation  
 L - SS Drip Pan  
 M - SS Gas Heat Exchanger  
 N - Dirty Filter Switch  
 P - Service Outlet (non-pwr)  
 Q - Service Outlet (pwr)  
 R - Split Power Fuse Disc.  
 S - Split Power Switch Disc.  
 T - Smoke SA  
 U - Smoke RA  
 V - Low Ambient Bypass  
 W - Economizer  
 X - Intertwined Evap. Coil  
 Y - Start Up  
 1 - 365 Day Annual Timer  
 2 - SOLAR HVAC  
 3 - Condensate Flow Switch  
 4 - Airflow Monitoring  
 5 - Hail Guard  
 6 - Fixed Powered Exhaust  
 7 - Phase Monitor  
 8 - Modulating Powered Exhaust  
 9 - Crate

## Configuration (13)

A - Down Supply / Down Return  
 B - Horizontal Supply / Down Return  
 C - Down Supply / Horizontal Return  
 D - Horizontal Supply / Horizontal Return

### WTR SRC CONFIG ONLY

E - Top Discharge / Rear Return  
 F - Top Discharge / Front Return  
 G - Front Discharge / Rear Return  
 H - Rear Discharge / Front Return  
 I - Right Discharge / Left Return  
 J - Back Discharge / Left Return  
 K - Left Discharge / Right Return



# - 15 16 17 18

## Wheel Diameter (15,16)

19 - 19"  
25 - 25"  
30 - 30"  
36 - 36"  
41 - 41"  
46 - 46"  
52 - 52"  
58 - 58"  
64 - 64"

## Airflow Capability (17)

L - Low  
H - High

## Options (18)

0 - No Options  
A - 2 Position Outside Air Damper  
B - 2 Position Exhaust Air  
C - Building Pressure  
D - Outside Airflow Monitoring  
H - Supply Air Filter Status  
J - Exhaust Air Filter Status  
K - Supply Air Blower Status  
L - Exhaust Air Blower Status  
M - With OA Blower  
N - Sensible Wheel  
P - Frost Protection



# ultraDRY NUMBERING SCHEME INSTRUCTIONS

## How to Translate ultraDRY Part Numbering Schemes

ultraDRY's part numbering scheme is composed of similar product identification, when compared to Carrier, in order to easily provide common options and features. By referencing the 2 character "type" in the beginning of each part number, it is easy to distinguish cooling only, gas heat, or heat pump models. A full list of Carrier unit model numbers is provided from by following the link in the web addresses listed above. Using the comparison below, an excerpt is provided from Carrier's technical guide to illustrate how a common unit can be traced from ultraDRY to Carrier.

### Asterisk

All part numbers and part number references will use an asterisk, \*, to designate all characters which do not apply to the part number for the information being provided in that section. Where an asterisk appears in the middle of a part number, the missing characters are irrelevant to the information being provided. Where the asterisk appears at the end of a part number, the remaining part number characters are irrelevant to the information being provided.

To determine the specific Carrier unit you need, see below for how to determine which Carrier manual you will need.

For more information about Carrier Commercial Split Units go to: <http://www.carrier.com/building-solutions/en/us/products/split-systems/split-systems/>

For more information about Carrier Commercial Units go to: <http://www.carrier.com/building-solutions/en/us/products/packaged-outdoor/outdoor-packaged-units/>

For more information about Carrier Residential Units go to: <http://www.carrier.com/homecomfort/en/us/products/heating-and-cooling/packaged-products/>

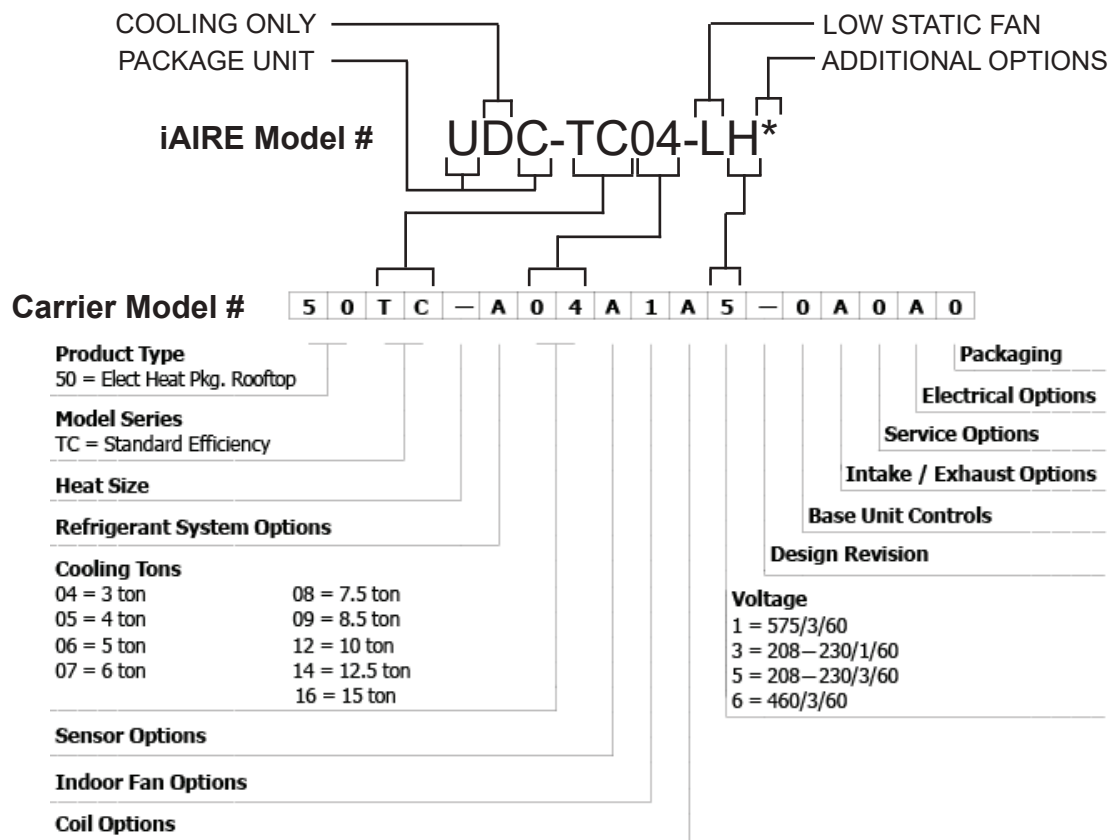

# START-UP REQUIREMENTS ! IMPORTANT !

**To maintain factory warranty, all units must have an authorized factory start-up and the start-up paperwork on file**

**For Questions, Contact iAIRE At:**

[www.myiaire.com](http://www.myiaire.com)

**Email:** [sales@myiaire.com](mailto:sales@myiaire.com)

**Phone:** 844-348-9168

**Fill out Start-Up request form here:**

<https://www.myiaire.com/support-service/service-request/>

## REFRIGERANT PIPING GUIDELINES

**IMPORTANT:** The information below is intended for general information on refrigerant piping only. Reference specific AHU and condensing units manuals for specific piping details.

The design of a refrigerant piping system should:

Ensure proper refrigerant feed to evaporators; Provide practical refrigerant line sizes without excessive pressure drop; Prevent excessive amounts of lubricating oil from being trapped in any part of the system; Protect the compressor at all times from loss of lubricating oil; Prevent liquid refrigerant or oil slugs from entering the compressor during operating and idle time; and Maintain a clean and dry system.

### REFRIGERANT LINE VELOCITIES

Economics, pressure drop, noise, and oil entrapment establish feasible design velocities in refrigerant lines. These are:

Suction line - 700 to 4,000 fpm

Discharge line - 500 to 3,500 fpm

Condenser drain line - 100 fpm or less

Liquid line - 125 to 450 fpm

Minimum Discharge- Line Velocities		
Refrigerant Velocity, fpm		
Nominal Pipe Size, in.	Riser	Horizontal
7/8	375	285
1-1/8	430	325
1-3/8	480	360
1-5/8	520	390
2-1/8	600	450

Higher gas velocities are sometimes found in relatively short suction lines on comfort air conditioning or other applications where the operating time is only 2,000 to 4,000 hrs per year and where the low initial cost of the system may be more significant than low operating cost.

Industrial or commercial refrigeration applications, where equipment runs almost continuously, should be designed with low refrigerant velocities for the most efficient compressor performance and low equipment operating cost.

The liquid line from the condenser to the receivers should be sized for 100 fpm or less to ensure positive gravity flow without incurring a backup of liquid flow. Liquid lines from the receivers to the evaporator should be sized to maintain velocities below 300 fpm, thus minimizing or preventing liquid hammer when solenoids or other electrically operated valves are used.

## LINE SIZING

In sizing refrigerant lines, cost considerations favor keeping the line size as small as possible. However, suction and discharge line pressure drops cause loss of compressor capacity and increased power usage.

Excessive liquid line pressure drops can cause the liquid refrigerant to flash, resulting in faulty expansion valve operation. Refrigeration systems are designed so that friction pressure losses do not exceed a pressure differential equivalent to a corresponding change in the saturation boiling temperature.

The primary measure for determining pressure drop is a change in saturation temperature. Pressure drop in a refrigerant line causes a reduction in system efficiency. Correct sizing must be based on minimizing cost and maximizing efficiency.

Pressure drop calculations are determined as normal pressure loss associated with a change in saturation temperature of the refrigerant. Typically, the refrigeration system will be sized for pressure losses of 2°F differential or less for each segment of the discharge, suction, and liquid lines. An HFC refrigerant liquid line is sized for pressure losses of 1° differential or less.

**IMPORTANT:** The information above is intended for general information on refrigerant piping only. Reference specific AHU and condensing units manuals for specific piping details.

## THERMOSTAT CONTROL

Uses a standard thermostat with a humidistat, a call for cooling turns on Y1, a call for heating turns on W1, a call for fan turns on fan. A humidity call (when there is no call for cooling) will turn on Y1 and also engage the modulating hot gas reheat valves.

## GENERAL INSTRUCTIONS

An iAIRE's operation is a function of the options and control packages that the iAIRE unit is equipped with.

\*\*\*Confirm that all unit clearances shown on the submittal are present around the unit. If the installation is on a roof with a parapet wall, make sure there is enough air flow through the condensing coil to not impact operations.\*\*\*

## RECEIVING / INSPECTION

**Check part # of iAIRE unit to ensure it is what was ordered.**

**Verify voltage/phases match.**

At the time of delivery the iAIRE unit should be visually inspected for possible damage. If any damage is found it should be reported immediately to the last courier company, preferably in writing.

## RIGGING

Utilize the Carrier factory information on rigging these units. If you need help accessing this information, please contact iAIRE customer service at: sales@myiaire.com or 844-348-9168. **Refer to IOM-0035 for ERV rigging.**

## SAFETY CONSIDERATIONS

Installation and servicing of the iAIRE units can be hazardous due to system, pressure, electrical components and moving parts. Only trained and qualified service personnel should install, repair or service these units.

When working on iAIRE or other HVAC units observe precautions in the literature, tags and labels attached to the units, and any other safety precautions that may apply.

*Follow all local, national and industry electrical codes when installing these units and accessories.*

## START-UP

### SPACE / DISCHARGE AIR TEMP CONTROL PACKAGE START-UP

#### Physical Inspection (pre power-up)

**Check part # of iAIRE unit to ensure it is what was ordered. Verify voltage/phases match.**

1. Verify condition of unit and note any installation or shipping damage to coils or cabinets.
2. Verify installation of condensate drain trap.
3. Verify power is available at disconnect and fuses are installed if required. Check incoming power to make sure it is within tolerance.
4. Verify that all airways are open. (Fire dampers and supply air registers.)
5. Check blower belt tension. (if available)
6. Confirm that the space sensor is installed. (Space Control units only, see wiring in figure "B" on installatoin wiring diagram pages. Space Sensors must be wired using shielded wire.

#### After power-up

1. Check incoming 3-phase power for a stinger leg if voltage is 208/230VAC. If so ensure that stinger leg (high voltage phase to ground) is the center leg.
2. Go to thermostat and set both the heat and cool CFM. The heat CFM is the VFD % in the heat mode that the AHU fan will run. The cool CFM is the VFD % the AHU fan will run in all other modes.
3. Remove panel from outside air section and verify outside air damper is fully open. Set adjustment thumb wheel on damper motor for full opening. Check crank arms and ball joints on damper mechanism allow damper to open fully.

#### Charging

1. Ensure Compressor VFD is running at 60Hz.
2. Disconnect 2-pin signal plug from Sporlan IB circuit board. This will close the modulating hot gas valve to allow correct charging.
3. Invert refrigerant jug to provide liquid charge into suction line and proceed to charge unit for 10 degrees of subcooling and 20 degrees superheat. Depending on ambient conditions, evaporator leaving air temperature should be between 48-58 °F.
4. When charge is complete return signal connector to Sporlan IB board and re-open Rawal ball valve.

5. Disconnect jumper from terminal strip input to allow the thermostat to take over machine.

6. Adjust sensor setpoint to a low setpoint to bring all cooling stages on and check if hot gas line warms up.

### TEST PROCEDURE

Verify operation as described above by monitoring liquid line temperature and observing motor speed.

#### Heater check

1. Verify Kw of installed electric heaters.

2. Disconnect white space temperature sensor wire from terminal strip. (This will make the thermostat see a space temperature of -40 degrees and start heaters) There is a five minute delay at start of heat cycle. With heater running check amperage and verify discharge air temperature.

3. Return white space temperature sensor wire to terminal strip.

#### Checking and adjusting system refrigerant charge.

Before connecting gauges to the systems suction and discharge service ports, make the following adjustments.

1. Before running blower and compressors, ensure Compressor VFD is running at 60Hz.

2. If Low Ambient is installed, shut off ball valve to low ambient and open bypass around low ambient to isolate L.A. valve.

3. Before running blower and compressors, put thermostat in TEST mode and manually set Hot Gas Valve % to 0.0% to direct all refrigerant to DX cooling.

a) Connect gauges. (Pre-load evacuated split systems with nominal weight of refrigerant)

b) Enable FAN and then Cool Stage 1 in TEST mode and allow several minutes for system to stabilize.

c) Note, high pressure saturation Temperature on gauge and the temperature of the Liquid Line leaving the condenser. (Condensing temperature should be 100-110 degrees minimum)

d) Calculate Sub cooling (Saturation Temp – Liquid line Temp = Sub cooling)

e) Charge systems for 12-15 degrees of sub cooling. Add refrigerant if sub cooling is low and remove if high. With all cooling stages enabled system should deliver 55 degree air, or less depending on ambient conditions.

f) Record sub cooling temperature \_\_\_\_\_ degrees

g) With thermostat still in TEST mode, increase the Hot gas valve position in increments until discharge air, (DAT) is raised to 70 - 72 degrees.

h) Record sub cooling temperature \_\_\_\_\_ Record evap saturation temperature \_\_\_\_\_

i) Let Compressor VFD run normal.

j) If Low Ambient is installed, open valve to low ambient and close valve to bypass Low Ambient.

k) Record sub cooling temperature \_\_\_\_\_ Record evap saturation temperature \_\_\_\_\_

l) Note: You can leave the TEST menu and enter the STATUS menu to check system temperatures at any time. TEST mode will remain active until it is manually disabled.

m) When charging and checks are complete, disable the TEST mode and let Compressor VFD run normal.

n) Allow system to stabilize and check sub cooling again.

o) Add/Remove refrigerant as necessary to maintain

about 4 degree of sub cooling.

p) Remove gauges and replace service port covers.

q) If charging for the first time note all required conditions in startup sheets and record weight of all refrigerant added.

#### Record Keeping

1. Record all readings and conditions in startup sheets and add notes to call attention to any issues for the unit installing contractor to attend to.

2. Have the startup documents signed by supervising foreman for mechanical contractor.

#### MODULATING GAS SETUP:

1: SEE IOM-0035 for standard carrier heat

2: SEE IOM-0035 for High Heat Box.

## TROUBLESHOOTING

1. The unit does not come on.
  - a. Check to make sure there is power to the unit.
  - b. Check to make sure the disconnect is on.
  - c. Check to make sure the jumper between pins on terminal strip 1 is removed.
    - i. If other wires are attached to pins, make sure there is not a short or the unit will not turn on. This is the location for remote start/stop.
  - d. Check to make sure the circuit breaker or the 24V power supply is not tripped.
2. Fan speed is not correct.
  - a. Go to the thermostat and adjust the fan speed up or down as required.
3. The unit is tripping out on high heat and requires a manual reset.  
The air speed needs to be raised to prevent the heat from being too hot in the unit.

## SEQUENCE OF OPERATIONS

### THERMOSTAT CONTROL

#### FAN SPEED CONTROL

These units are equipped with variable speed supply fan control. There is a cooling and heating fan speed set point. In this application, both the cooling and heating fan speed set point should be the same. This should be set by the test and balance contractor to provide and correct CFM for the unit. Once the supply fan speed is initially set, it will not modulate.

#### NORMAL HOURS (not night set back)

Cooling Mode(humidistat on cooling) –When the temperature gets above the set point temperature by more than 2 degrees, the compressor will come on and start cooling the air. Once the temperature reaches the set-point, the compressor will turn off and the air will continue to circulate in the space without heating or cooling.

Heating Mode (humidistat on heating) – When the temperature gets below the set point temperature by more than 2 degrees, the heat pump will come and begin heating the air. Once the temperature reaches the set point temperature, the heat pump will turn off and the air will continue to circulate in the space without heating or cooling.

Humidity mode – When the unit is not running in cooling or heating and the humidity sensor on the humidistat registers a humidity higher than the set point humidity, the compressor will come on for cooling and the hot gas on/off valves will open to raise the discharge temperature of the air entering the building after cooling. This will help reduce the humidity without cooling the building off too much. Once the humidity is below the set point humidity, the unit compressor and hot gas on/off valves will shut off and the air will continue to circulate in the space without heating or cooling.

#### NIGHT SET BACK HOURS

Allows the occupant to set a schedule across the 7 day, 24 hour week to schedule set back temperatures at night to conserve energy.

#### UNOCCUPIED HOURS

Allows the occupant to set a schedule across the 7 day, 24 hour week to schedule the unit off to conserve energy.



## STATUS MENU

### COMP 1 STATUS

Comp 1 OFF  
**RANGE:** OFF or Fan Speed (Slow) %

### LIQUID PRESSURE STATUS (LIQUID CONFIG ONLY)

Heat: \*\*\*PSI  
 Cool: \*\*\*PSI  
**RANGE:**  
 0-999 PSI  
**NOTE:** Select Config Type in  
 Version/Config Menu -->  
 Config Settings-->

### SUCTION PRESSURE STATUS (SUCTION CONFIG ONLY)

Heat: \*\*\*PSI  
 Cool: \*\*\*PSI  
**RANGE:**  
 0-999 PSI  
**NOTE:** Set Pressure Ctrl Operation  
 (Default: Suction 1 SP)

### OUTSIDE AIR TEMP STATUS

Outside Temp: \*\*\*. \* F

### INPUT 1 STATUS

Y1: 0  
 O/W1: 0  
**RANGE:** 0 = OFF / 1 = ON

### ALARM STATUS

Raw: \*\*\*\* (Range: 0000-9999)  
 Volt: \*. \* (Range: 0.0 - 9.9V)  
 Status: OK (Range: OK or Fault)

### DEFROST STATUS

Defrost Off, Time to OAT Chk 3600S

## TEST MODE MENU

### TEST MODE ENABLE/DISABLE

**DEFAULT:** Test Mode: Disabled

### AO1 TEST

AO1 output \*\*\*%  
**Default:** 000%  
**Range:** 0-100%

### AO2 TEST

AO2 output \*\*\*%  
**Default:** 000%  
**Range:** 0-100%

### DO1 TEST

DO1 output OFF  
**Default:** OFF  
**Range:** On / Off

### DO2 TEST

DO2 output OFF  
**Default:** OFF  
**Range:** On / Off

### DO3 TEST

DO3 output OFF  
**Default:** OFF  
**Range:** On / Off

### DO4 TEST

DO4 output OFF  
**Default:** OFF  
**Range:** On / Off

## SETPOINT MENU

### COOL PRESSURE SETPOINT

Cool Press. SP \*\*\*  
**Default:** 170  
**Range:** 0-450

### DEFROST START TEMP

Def Start Temp \*\*F  
**Default:** 45F  
**Range:** 0-50F

### DEFROST RUN TIME

Def Run Time \*\* Min  
**Default:** 05 Min  
**Range:** 1-30 Min

### HP RUN TIME

HP Run Time \*\* Min  
**Default:** 60 Min  
**Range:** 05-90 Min

### CRANKCASE SETPOINT

Crankcase SP \*\*F  
**Default:** 45F  
**Range:** 0-55F

### COMPRESSOR START SPEED

Comp. Setpoint \*\*\*%  
**Default:** 078%  
**Range:** 039-100%

### COMPRESSOR LOW LIMIT

Comp. Setpoint \*\*\*%  
**Default:** 075%  
**Range:** 001-100%

### LOW LIMIT TIME

Low Limit Time \*\*\* Min  
**Default:** 030 Min  
**Range:** 001-120 Min

### OIL RETURN TIME

Override Time \*\* Min  
**Default:** 03  
**Range:** 00-60 Min

## VERSION/CONFIG MENU

### VERSION \*.\*

### CONFIG SETTINGS

#### Controller Mode Configuration:

Res HP (Enabled)  
 Range: Res HP / Res Cool /  
 Commercial

#### Configure Sec X Min:

# of Seconds per Min \*\*  
 Range: 10 - 60

#### Oil Return:

Oil Return Off Enabled  
 Range: On / Off

#### BAS Config:

No BAS (Enabled)  
 Range:  
 No BAS  
 Yes, BAS Active

#### Load Defaults:

Are You Sure?????:

#### Set Fast Rate:

X \* .25 Sec  
 \*\*\* <setting>  
 Default: 002  
 Range: 001 - 100

#### Set Slow Rate:

X \* .25 Sec  
 \*\*\* <setting>  
 Default: 010  
 Range: 001 - 50

#### Set Slow Point:

Slow Point \*\*\*  
 Default: 020  
 Range: 0-100%

#### Set Pressure Ctrl Operation:

Suction 1 SP [Enabled]  
 Range:  
 Liquid / Suction 1 SP

**NAVIGATING ON VICONICS THERMOSTAT:**

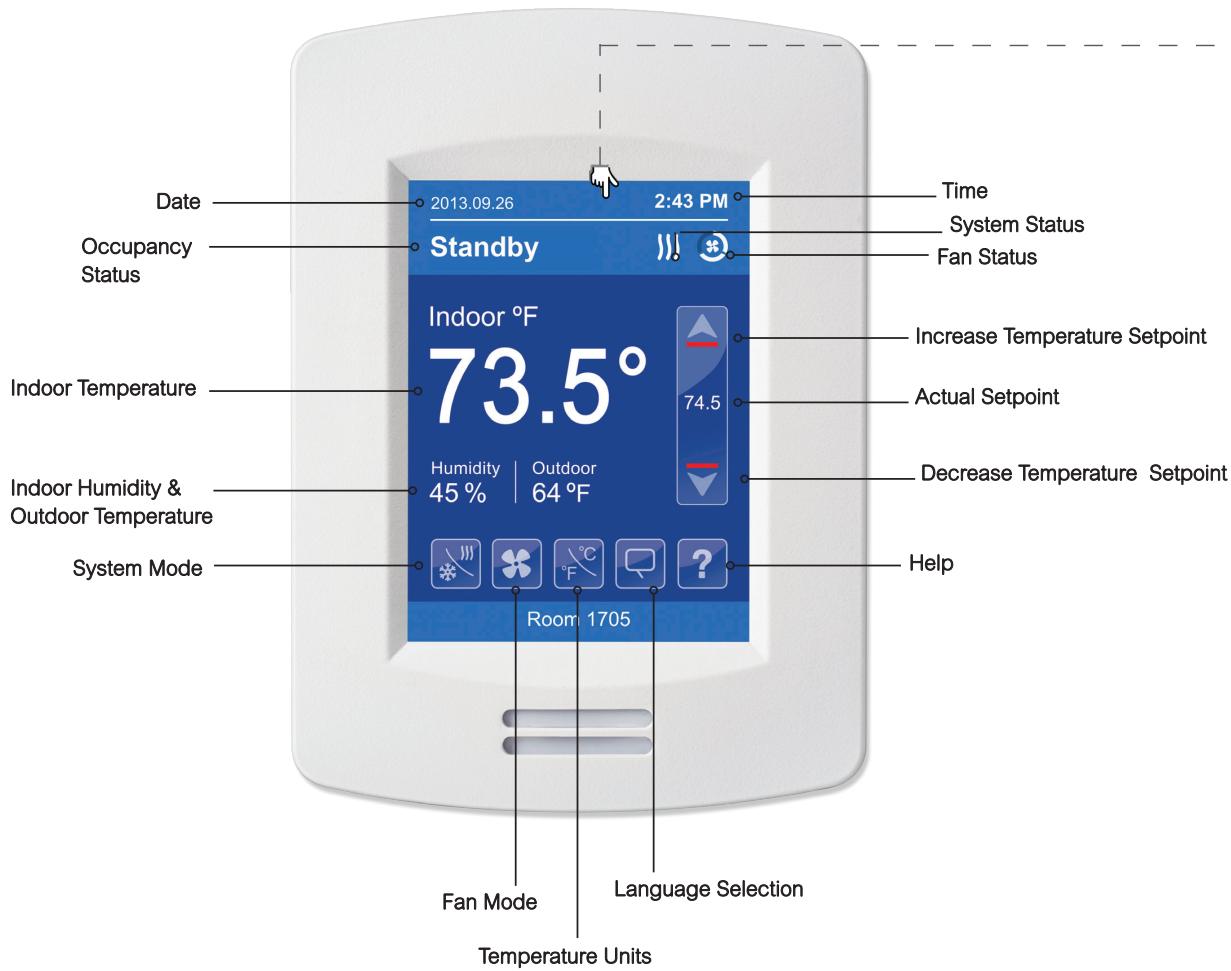

— Touch and hold this point for 3 seconds to enter setup mode

**Note:** If a configuration/installer password is activated to prevent unauthorised access to the configuration menu parameters, a password entry prompt shows to prevent access to device configuration components.

**ADVANCED MENU NAVIGATION:**

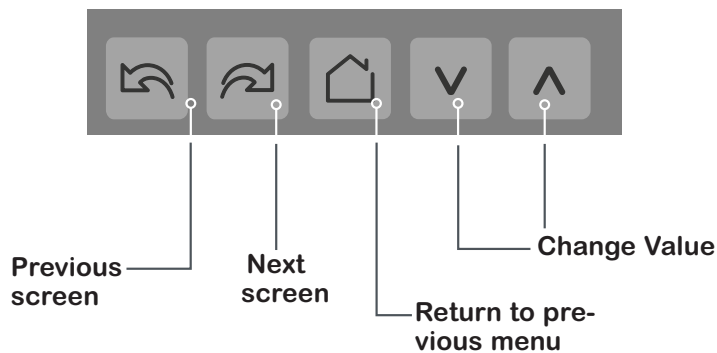

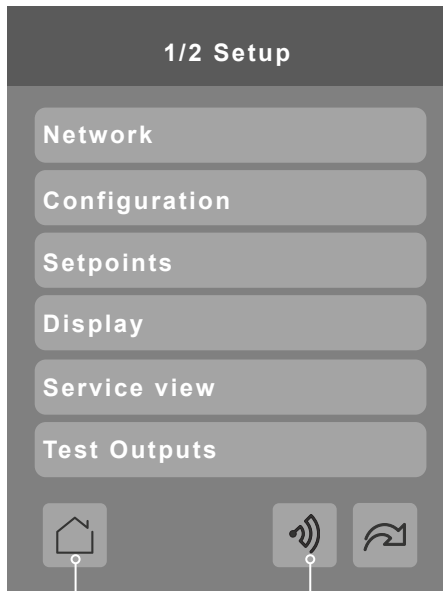
**ADVANCED MENU****SETUP MENUS:****THERMOSTAT MOD HEAT**

Return to previous menu

**Discover Mode** shows wireless ZigBee network. Icon not shown if ZigBee communication module not installed

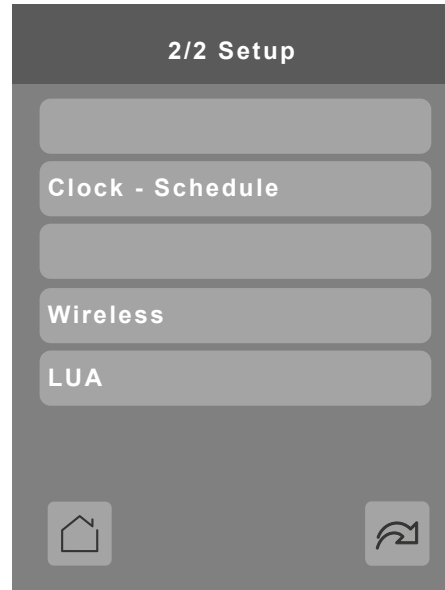
**DEFAULT SETTINGS TABLE:**

SETUP OPTION	SUB-OPTION	PAGE	MENU OPTIONS	DEFAULT SETTING
<b>Network</b>	-	1/1	Onboard prot.	None
			Optional prot.	None
			Wired protocol	BAC MSTP
	BACnet Network	1/2	COM address	254
			Network units	Imperial
			Network lang.	English
			Baud rate	Auto
			BACnet status	Offline
			BACnet PRate	4
			BACnet Network Code	86253
<b>Configuration</b>	-	1/11	UI16 config	None
			UI17	None
			UI19	None
			UI20	RS
			Setpoint func	Attach SP
			Mode button	Normal

## DEFAULT SETTINGS TABLE: (CONT.)

SETUP OPTION	SUB-OPTION	PAGE	MENU OPTIONS	DEFAULT SETTING
<b>Configuration (cont.)</b>	-	2/11	Fan Cont. Heat	On
			Fan Delay	On
			Standby Mode	Absolute
			Standby Diff.	4.0° F
			Power-up Delay	10 Seconds
			Occupancy Source	Motion
	-	3/11	Standby Time	0.5 hrs
			Unoccupied Time	0.0 hrs
			Temp. Occ. Time	2.0 hrs
			Temp. Sensor	Internal
			Deh. Hysteresis (*1)	2% RH
			Dehum. Function (*2)	Enable
	-	4/11	Cooling CPH (*3)	4
			Heating CPH (*4)	4
			Frost Protection	Off
			B01 Aux. Configuration	No
			Anti Short Cycle	2 Minutes
			Min Supply Heat	64.0° F
	-	5/11	Prop. Band	3
			Heat Stages	2
			Cool Stages	2
			Econo. Config.	Off
			Changeover SP	55.0° F
			Mech. Cooling	Off
	-	6/11	Heat Lockout	120.0° F
			Cool Lockout	-40.0° F
			Discharge HL	120.0° F
			Discharge LL	45.0° F
			SH Lockout	32.0° F
			FA Range	0 CFM
	-	7/11	Econo. Min. Pos.	0%
			Econo. Max. Pos.	100%
			Min. Fresh Air	0 CFM
			Max. Fresh Air	0 CFM
			Min. CO2	800 PPM
			Max. CO2	1200 PPM
	-	8/11	Application	Rooftop
			High BP	90.0 ° F
			Low BP	-12.0° F
			Comfort Or Economy	Comfort
Reversing Valve			0	
Comp. Interlock			Off	

**DEFAULT SETTINGS TABLE: (CONT.)**

SETUP OPTION	SUB-OPTION	PAGE	MENU OPTIONS	DEFAULT SETTING	
<b><u>Configuration (cont.)</u></b>	-	9/11	Main Password	0	
			User Password	0	
			Schedule Menu	Enabled	
			USB Access	Enabled	
			Smart Recovery	Off	
	-	10/11	Calibration Temp.	0.0 ° F	
			Calibration OS Temp.	0.0 ° F	
			Calibration Humidity	0.0% RH	
			RH Sensor	Internal	
			CO2 Source	Local	
	Reinitialization	11/11	Erase All?	No	
	<b><u>Setpoints</u></b>	-	1/2	Unoccupied Cool	80.0 ° F
				Standby Cool	78.0 ° F
Occupied Cool				74.5 ° F	
Occupied Heat				71.5 ° F	
Standby Heat				69.0 ° F	
Unoccupied Heat				62.0 ° F	
-		2/2	Default Heat	72.0 ° F	
			Min. Deadband	3.0 ° F	
			Max. Heating	90.0 ° F	
			Min. Cooling	54.0 ° F	
			Supply Air SP	55.0 ° F	
			Dehum. SP	50% RH	
			<b><u>Display</u></b>	-	1/3
Color	Orange				
Main Display	Temp.				
Standby Screen	No				
Lock Screen	No				
Contrast	-2				
-	2/3	Language		English	
		Units		F	
		Low Backlight		60%	
		Night Backlight		5%	
		RH Display		Disabled	
-	3/3	CO2 Display		Disabled	
		Fan Status		Enabled	
		SYstem Status	Enabled		
		Help Button	Enabled		

**DEFAULT SETTINGS TABLE: (CONT.)**

SETUP OPTION	SUB-OPTION	PAGE	MENU OPTIONS	DEFAULT SETTING
<b>Service View</b>	-	1/10	Room Temperature	89.5° F
			UI20 Temperature	-40.0° F
			Outdoor Temperature	-40.0° F
			Supply Temperature	40.0° F
	-	2/10	Effective Occ.	Occupied
			PI Cool Demand	100%
			PI Heat Demand	0%
			Cool Dem. Limit	0%
			Heat Dem. Limit	0%
			Econo. Demand	0%
	-	3/10	UI16 Binary	Not Activated
			UI17 Binary	Activated
			UI19 Binary	0.0 Vdc
			Airflow Level	0 CFM
	-	4/10	Window Alarm	Off
			Service Alarm	Off
			Filter Alarm	Off
			CO2 Alarm	Off
			Low Air Alarm	Off
	-	5/10	Frost Alarm	Off
			Recovery	Off
			Local Motion	No Motion
			Deh. Status	Off
			Room Humidity	77% RH
	-	6/10	UO9 Configuration	Analog
			UO10 Configuration	Analog
			UO11 Configuration	Analog
			UO12 Configuration	Analog
	-	7/10	UI19 Type	Voltage
			UI20 Type	Voltage
			UI22 Type	Therm.
			UI23 Type	Therm.
			UI24 Type	Voltage
-	8/10	CO2 Eff. Source	None	
		CO2 Err. Code	0x0000	
		CO2 Level	0 PPM	
		CO2 FW Rev.	-	
		CO2 S/N	-	
-	9/10	Eff. System Mode	Cool	
		Eff. Setpoint	71.5° F	

**DEFAULT SETTINGS TABLE: (CONT.)**

SETUP OPTION	SUB-OPTION	PAGE	MENU OPTIONS	DEFAULT SETTING
<b><u>Test Outputs</u></b>	-	1/2	BO1 Aux. Out	Off
			G Fan Status	On
			Y1 Status	On
			Y2 Status	On
			W1 Status	Off
			W2/OB Status	Off
	-	2/2	UO10 Analog	0.0 Vdc
			UO11 Analog	0.0 Vdc
			UO12 Binary	Off
<b><u>Language Selection</u></b>	-	1/4	French	Disabled
			Spanish	Disabled
			Chinese	Disabled
			Russian	Disabled
			Arabic	Disabled
			Czech	Disabled
	-	2/4	Danish	Disabled
			Dutch	Disabled
			Finnish	Disabled
			German	Disabled
			Hebrew	Disabled
			Hungarian	Disabled
	-	3/4	Indonesian	Disabled
			Italian	Disabled
			Japanese	Disabled
			Norwegian	Disabled
			Polish	Disabled
			Portugese	Disabled
	-	4/4	Slovak	Disabled
			Swedish	Disabled
Turkish			Disabled	
<b><u>Clock - Schedule</u></b>	Clock	1/2	Time Format	AM-PM
			Time	10:43 AM
			Year	2000
			Month	Jan.
			Day	6
			Weekday	Saturday
	Schedule	1/1	Occupied 1	--:--
			Unoccupied 1	--:--
			Occupied 2	--:--
			Unoccupied 2	--:--
			Occupied 3	--:--
Unoccupied 3			--:--	
Options	1/1	Occupancy Cmd	Occupied	
		Schedule Type	7 Days	

**DEFAULT SETTINGS TABLE: (CONT.)**

SETUP OPTION	SUB-OPTION	PAGE	MENU OPTIONS	DEFAULT SETTING
<b>ADR</b>	-	1/1	Permission	Off
			Shed Status	Off
			Shed Demand	Off
			Shed Offset	4.0 °F
			Shed Override	Off
<b>Lua</b> (Custom menu containing VFD speed setpoint and HGRH min. and max.)	-	2/4	Program Cmd	Run
			Program Status	Running
			Program Error	No Error
	-	3/4	VFD Speed %	95
			HGRH Min. %	2
			HGRH Max. %	75
			SatOffsetDeg (*5)	3
			DehClgOffset (*6)	0
			SatPBand	-
	-	4/4	OatHumid%	0
			Param. H AV226	0
			Param. I AV227	0
			Param. J AV228	0
Param. K AV229			0	
			Param. L AV230	0

**\* NOTES:**

1: Dehumidification deadband. Dehum Enables at setpoint then stays active to Dehum SP – Deh. Hysteresis

2: Enable = Hot Gas Reheat Enable - Disable = Hot Gas Reheat Disable

3: Number of maximum cycles per hour

4: Number of maximum cycles per hour

5: Hot gas reheat or “dehumidification” = “active”. This is the DAT setpoint offset from room temperature. If SAToffsetDeg = 1 and room temperature setpoint = 75, when in dehumidification discharge air setpoint will be equaled to 75degF minus 1, thus 74 degF.

Setpoint to be 0 to 10 deg offset.

6: This is how far past setpoint it will still enable and keep dehumidification active. This allows to enable and stay in dehumidification below room temperature setpoint.

## THERMOSTAT CONTROL - BACNET POINTS LIST

OBJECT ID	Description	Point Type	BacNET Name	BacNET Object	Object Type	Read Access
1	Occupancy Command	MULTI	Occupancy Command	MULTI_STATE_VALUE:10	MSV	READ / WRITE
2	Control System Mode	MULTI	System Mode	MULTI_STATE_VALUE:16	MSV	READ / WRITE
3	Fan Control Mode	MULTI	Fan Mode	MULTI_STATE_VALUE:17	MSV	READ / WRITE
4	Thermostat Time Source	MULTI	Time Source	MULTI_STATE_VALUE:325	MSV	READ / WRITE
5	Occupancy Status	MULTI	Effective Occupancy	MULTI_STATE_VALUE:33	MSV	READ ONLY
6	Supply/Discharge Air Temp	ANALOG	UI22 Supply Temperature	ANALOG_VALUE:102	AI	READ ONLY
7	Thermostat Room Temperature	ANALOG	Room Temperature	ANALOG_VALUE:100	AI	READ / WRITE
8	VFD Speed Setpoint	ANALOG	Lua Parameter A (AV25)	ANALOG_VALUE:25	AO	READ / WRITE
9	User Password (change SP & Mode)	ANALOG	User Password	ANALOG_VALUE:57	AI	READ / WRITE
10	Main Password (change configuration)	ANALOG	Main Password	ANALOG_VALUE:56	AI	READ / WRITE
11	Dehumidification Setpoint	ANALOG	Dehumidification Setpoint	ANALOG_VALUE:71	AI	READ / WRITE
12	Occupied Cool Setpoint	ANALOG	Occupied Cool Setpoint	ANALOG_VALUE:40	AI	READ / WRITE
13	Occupied Heat Setpoint	ANALOG	Occupied Heat Setpoint	ANALOG_VALUE:39	AI	READ / WRITE
14	Unoccupied Cool Setpoint	ANALOG	Unoccupied Cool Setpoint	ANALOG_VALUE:44	AI	READ / WRITE
15	Unoccupied Heat Setpoint	ANALOG	Unoccupied Heat Setpoint	ANALOG_VALUE:43	AI	READ / WRITE
16	Hot Gas Reheat Output	ANALOG	UO12 Analog Output	ANALOG_OUTPUT:124	AO	READ ONLY
17	Dehumidification Status	ANALOG	Dehumidification Status	BINARY_VALUE:38	BO	READ ONLY
18	W2 or OB Output Status	ANALOG	W2/OB Status	BINARY_OUTPUT:29	BO	READ ONLY
19	W1 Output Status	ANALOG	W1 Status	BINARY_OUTPUT:28	BO	READ ONLY
20	Y2 Output Status	ANALOG	Y2 Status	BINARY_OUTPUT:27	BO	READ ONLY
21	Y1 Output Status	ANALOG	Y1 Status	BINARY_OUTPUT:26	BO	READ ONLY
22	G Output Status	ANALOG	G Fan Status	BINARY_OUTPUT:25	BO	READ ONLY
23	Fan Input Status	ANALOG	UI16 Binary Input	BINARY_INPUT:29	BI	READ ONLY
24	Thermostat Room Humidity	ANALOG	Room Humidity	ANALOG_VALUE:103	AO	READ ONLY

## Residential Split Troubleshooting

### 9. Troubleshooting

#### 9.1. Control logic description

##### 1. Display board button function

▲ button: check button、setting button“+”

▼ button: check button、setting button“-”

■ button:

A、Short press: force cooling mode, display board will show “dH”;

B、Long press: entering test mode, and you can change unit parameter manually:

When it show “Sc.”, then you can set Compressor Frequency manually, using “▲” and “▼”to change frequency.

Then press “■” button, display board will show “SF.”, then you can set fan speed manually, using “▲” and “▼”to change fan speed.

Then press “■” button, display board will show “SL.”, then you can set expansion valve open degree manually, using “▲” and “▼”to change expansion valve opening degree.

Then press “■” button, display board will show “SP.”, then you can set PFC switch manually, (0 means OFF, 1 means ON), using “▲” and “▼” to set PFC switch ;

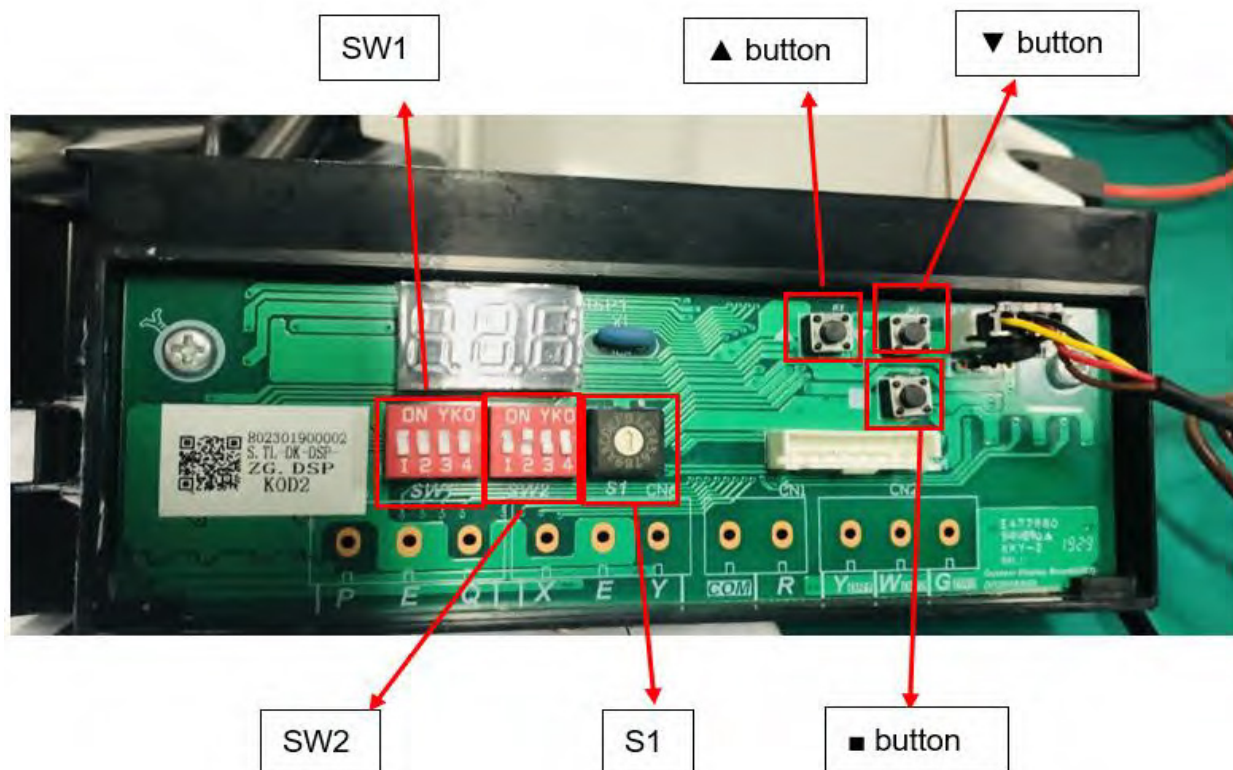

## Residential Split Troubleshooting (cont'd)

SW1:

1st bit	2nd bit	3rd bit	4th bit
Outdoor unit control logic(target evaporator temperature and target condensation temperature) setting, manufacture only.			ON: EXV throttling in cooling mode OFF: Piston throttling in cooling mode The function will be active after unit power off and power on.

SW2:

1st bit	2nd bit	3rd bit	4th bit
ON: Manually defrost. OFF: Automatic defrost The function will be active immediately after bit change.	ON: Display as Fahrenheit OFF: Display as Celsius The function will be active after unit power off and power on.	Reserved	ON: EXV throttling in heating mode OFF: Piston throttling in heating mode The function will be active after unit power off and power on.

S1: Reserved

## Residential Split Troubleshooting (cont'd)

### 9.2 Parameter point check table

#### 1). Top discharge outdoor unit

For 24/36K model

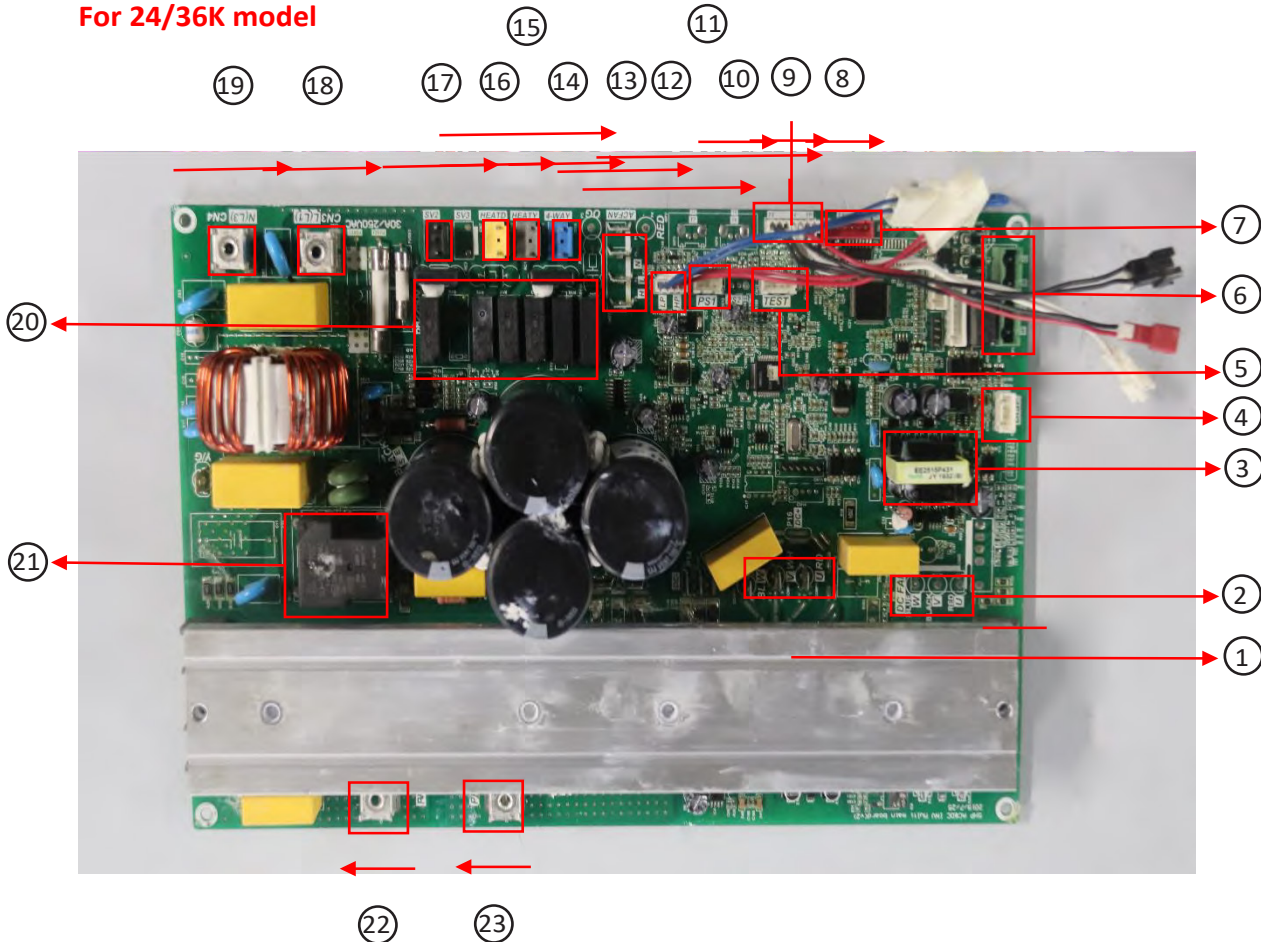

#### Function description for the corresponding position:

No.	Content	No.	Content
1	Compressor wiring terminal	12	High/Low pressure switch ports
2	DC fan motor wiring terminal	13	AC fan motor wiring terminal
3	Transformer	14	Four-way valve control port
4	Outdoor display board wiring terminal	15	Crankcase Heating zone control terminal
5	Reserved	16	Chassis Electric Heater control terminal
6	24V wire controller interface	17	Solenoid valve2 control terminal
7	EXV drive port	18	Power supply connecting terminal
8	Exhaust temperature sensor port(T5)	19	Power supply connecting terminal
9	Outdoor ambient temperature sensor port(T4)	20/21	Relay
10	Condenser temperature sensor port(T3)	22	Inductor wiring terminal 1
11	Pressure sensors ports	23	Inductor wiring terminal 2

## Residential Split Troubleshooting (cont'd)

For 48/60K model

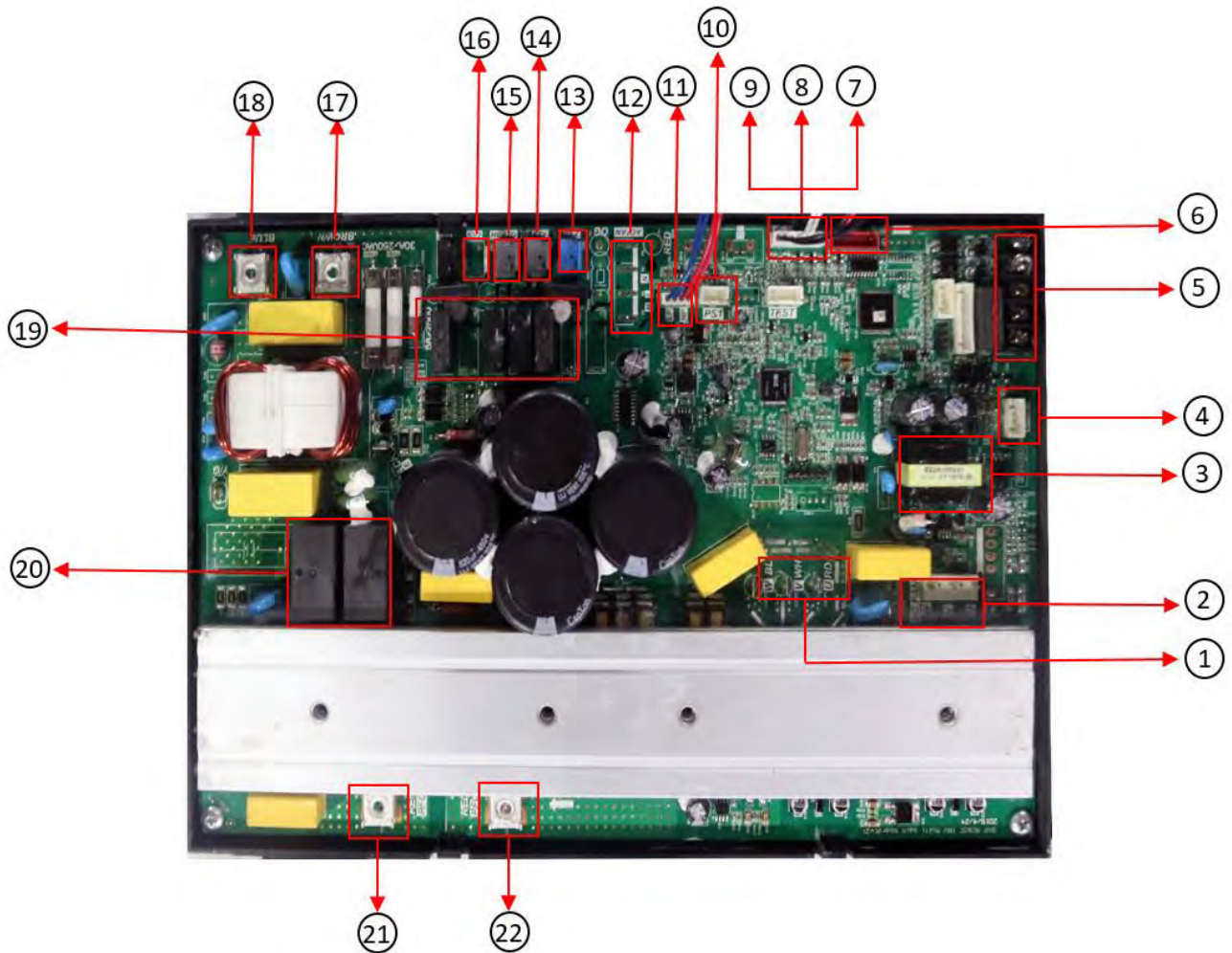

Function description for the corresponding position:

No.	Content	No.	Content
1	Compressor wiring terminal	12	AC fan motor wiring terminal
2	DC fan motor wiring terminal	13	Four-way valve control port
3	Transformer	14	Crankcase Heating zone control terminal
4	Outdoor display board wiring terminal	15	Chassis Electric Heater control terminal
5	24V wire controller interface	16	Solenoid valve control terminal
6	EXV drive port	17	Power supply connecting terminal
7	Exhaust temperature sensor port(T5)	18	Power supply connecting terminal
8	Outdoor ambient temperature sensor port(T4)	19	Relay
9	Condenser temperature sensor port(T3)	20	Relay
10	Pressure sensors ports	21	Inductor wiring terminal 1
11	High/Low pressure switch ports	22	Inductor wiring terminal 2

## Residential Split Troubleshooting (cont'd)

### 9.3 Error codes

CODE	FAULT DESCRIPTION
E4	T4 Outdoor ambient temperature sensor error
E5	T5 Discharge temperature sensor error
E6	T3 Condenser temperature sensor error
E9	AC under voltage protection
E10	EEPROM error
E12	IPM modular sensor error
E13	HLP Pressure sensor error
E14	T3 or T5 sensor disconnect error
E15	High pressure switch error
H0	Communication error of main chip and IPM chip
H1	T3 sensor high temperature error(In cooling mode) (20 times P5 error within 180mins)
H2	High pressure switch error(20 times P1 error within 150 mins)
H3	High pressure abnormal in heating mode (20 times P13 error within 180 mins)
H4	IPM modular high temp error (20 times P8 within 120 mins)
H5	Low pressure error (20 times P2 within 100 mins)
H6	Discharge temperature abnormal error(20 times P4 within 100 mins)
H7	Wet operation error (20 times P12 within 200 mins)
H8	T3 condenser sensor disconnect error (20 times E14 within 100 mins)
H12	Discharge temp sensor disconnect error(20 times E14 within 180 mins)
P1	High pressure protection
P2	Low pressure protection
P3	DC over current protection
P4	T5 Discharge temperature abnormal error
P5	T3 Condenser sensor high temp protection(In cooling mode)
P6	IPM module protection
P8	IPM high temperature protection (Ft)M high temperature protection (Ft)
P9	DC fan motor error
P12	Wet operation error
P13	High pressure abnormal error(In heating mode)
P14	High compression ratio protection
P15	Low compression ratio protection
L1	DC cable bus low voltage protection

## Residential Split Troubleshooting (cont'd)

### 9.3 Error codes continued

L2	DC cable bus high voltage protection
L4	MCE fault / sync / closed loop
L5	Zero speed protection
L7	Compressor phase loss protection ratio protection
L8	Compressor stalls
L9	Frequency limitation or decline by high pressure
LA	Frequency limitation by voltage
LC	Frequency limitation by condenser temp.
LD	Frequency limitation by discharge temp
LE	Frequency limitation by IPM modular high temp
LF	Frequency limitation by current
d0	Oil return
dF	Defrost
dH	Force cooling

## Residential Split Troubleshooting (cont'd)

### 9.4 Troubleshooting guidelines

**E4/E5/E6** (T4/T5/T3 temperature sensors error)

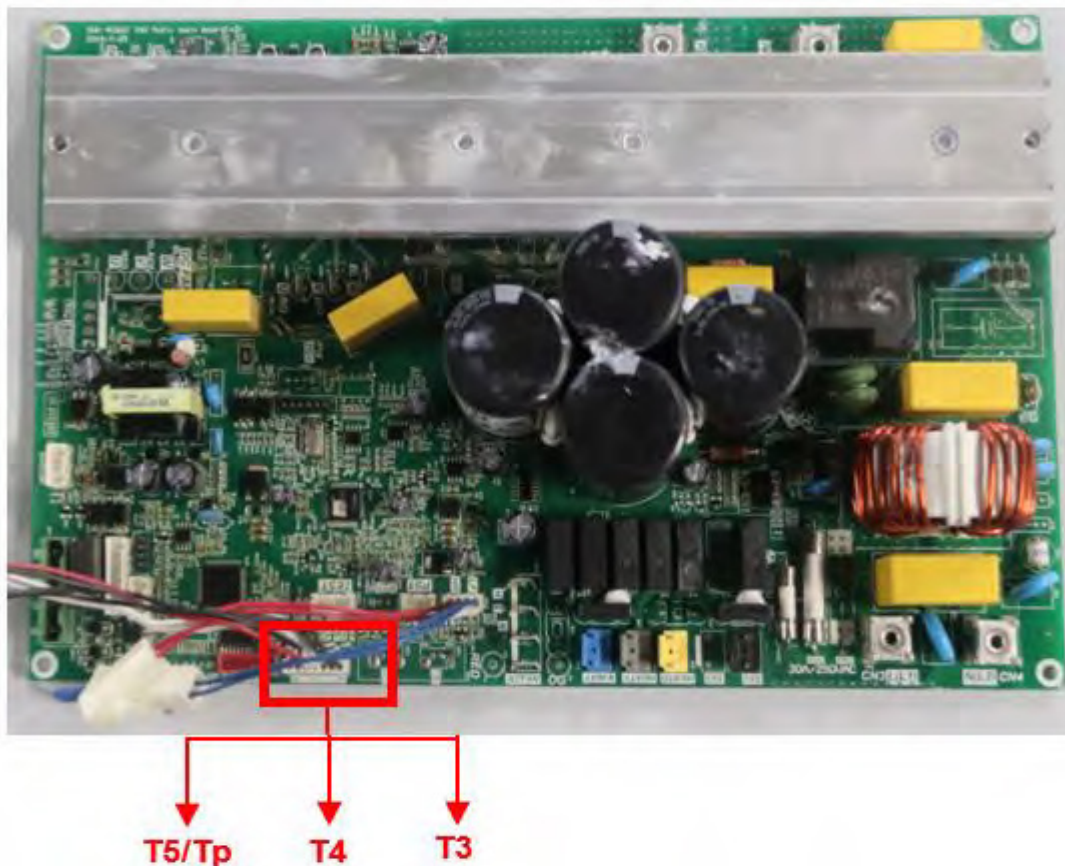
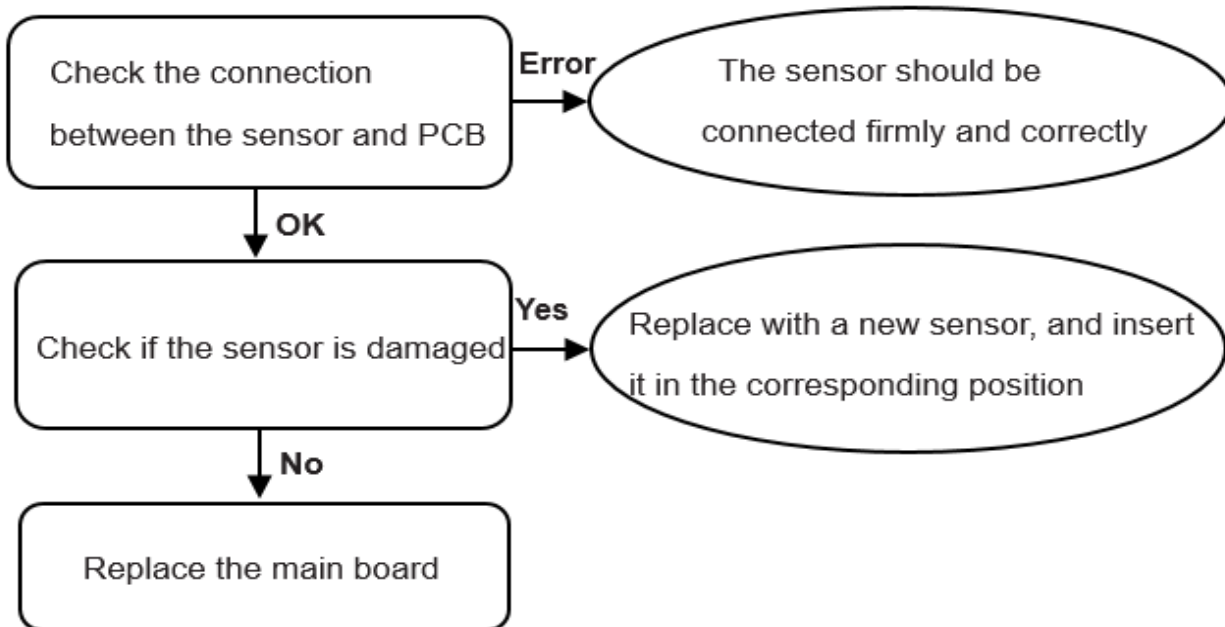

## Residential Split Troubleshooting (cont'd)

### E9 ( AC under voltage protection )

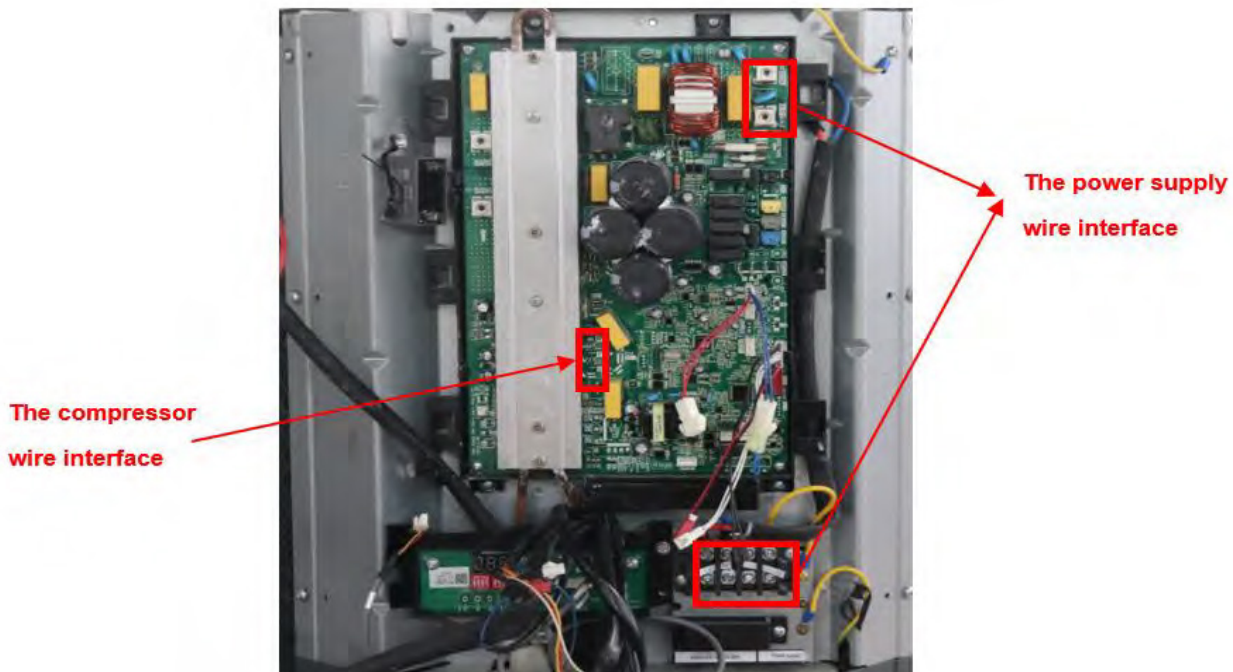
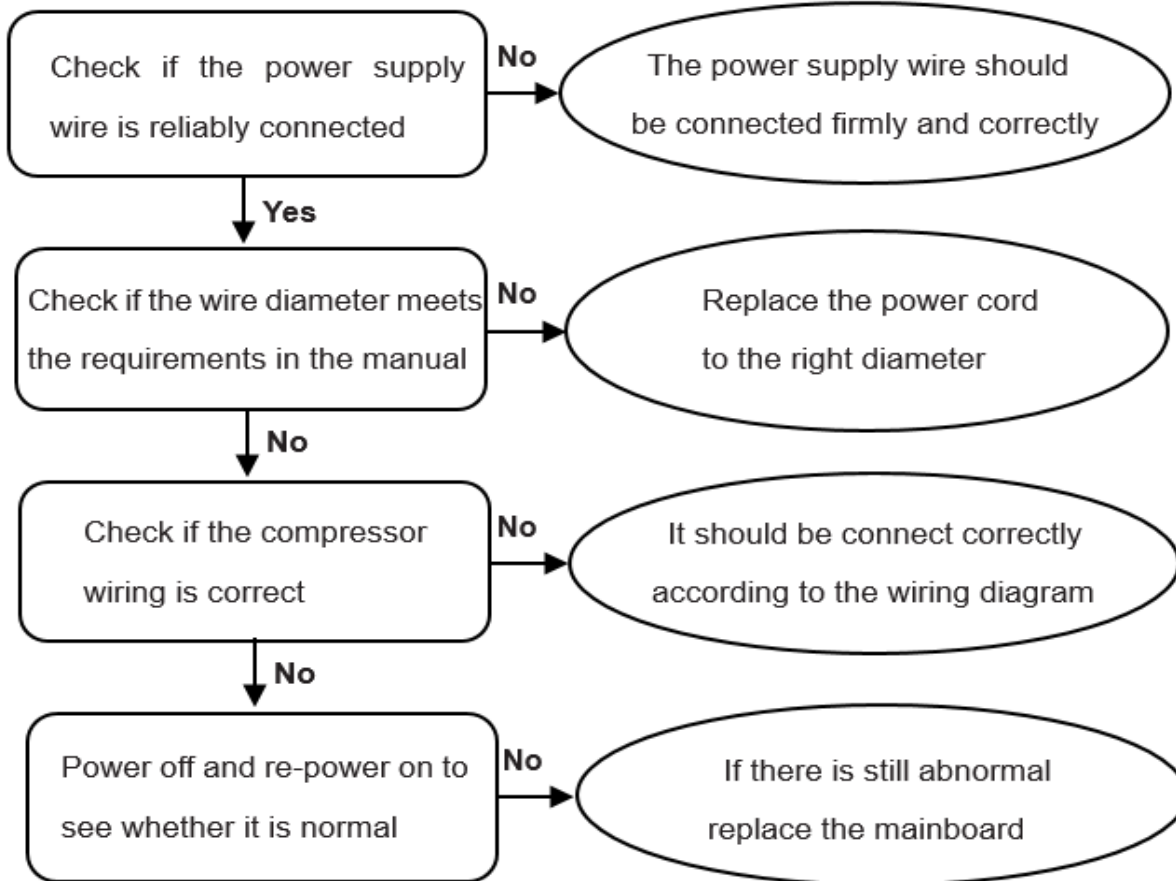

## Residential Split Troubleshooting (cont'd)

### E10 (EEPROM failure)

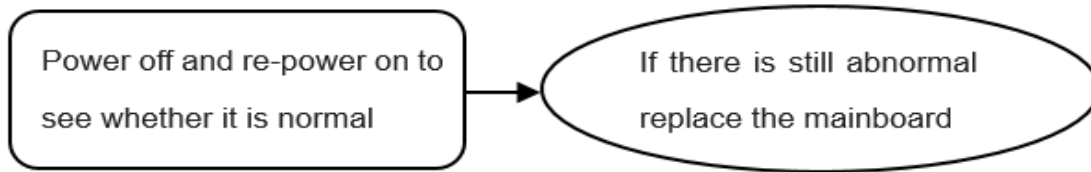

### E12 (IPM modular sensor error)

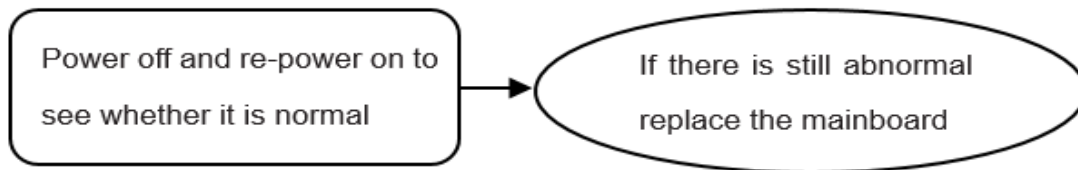

### E13 (HLP Pressure sensor error)

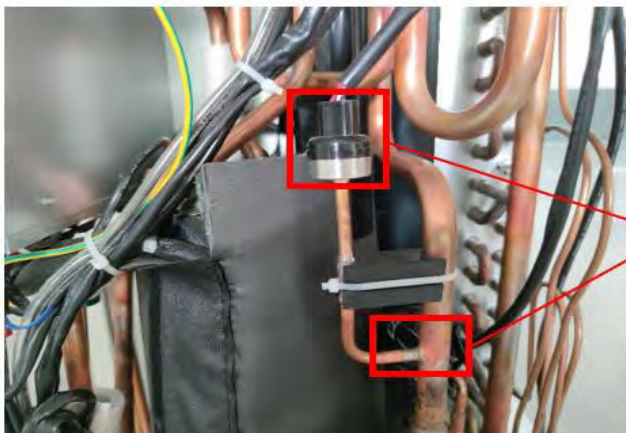
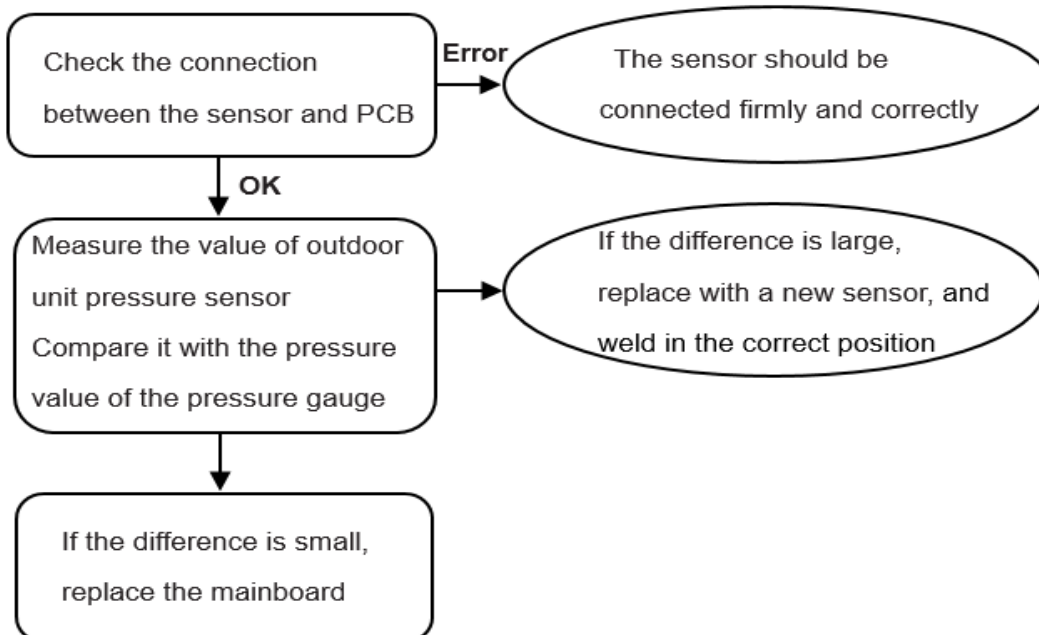

The pressure sensor should be soldered in the correct position

## Residential Split Troubleshooting (cont'd)

### E14/H8/H12 ( T3 or T5 sensor disconnect error )

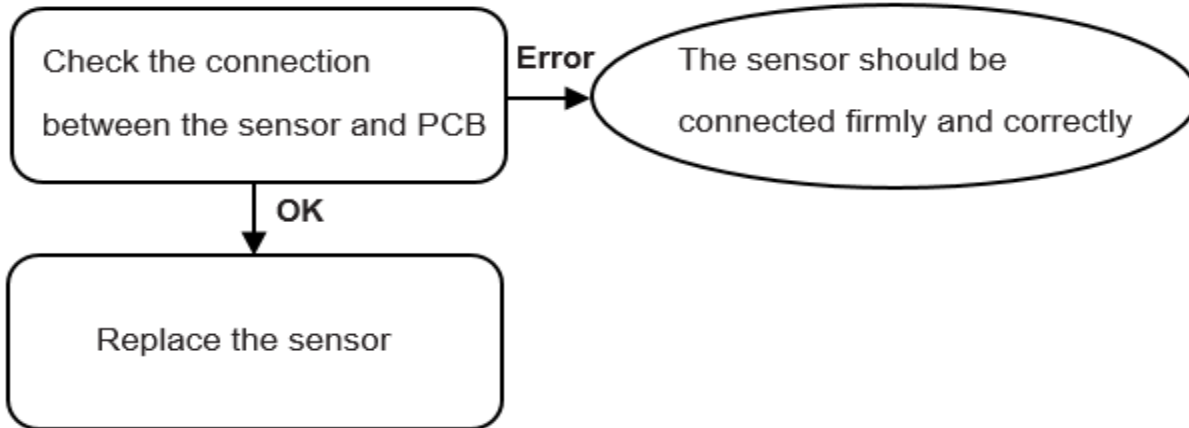

### E15 ( High pressure switch error )

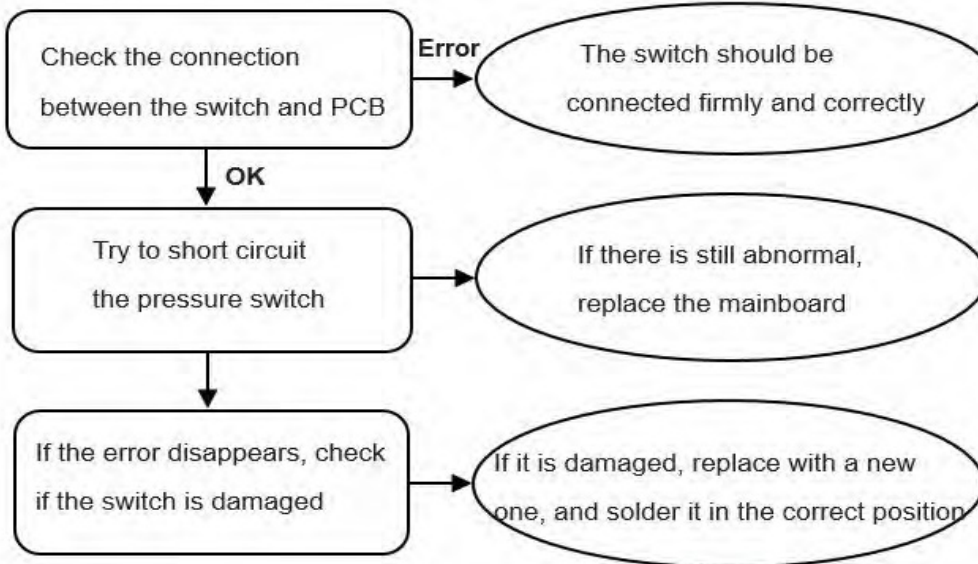

**The high pressure switch should be soldered in the correct position**

## Residential Split Troubleshooting (cont'd)

**H0** (Communication error of main chip and IPM chip )

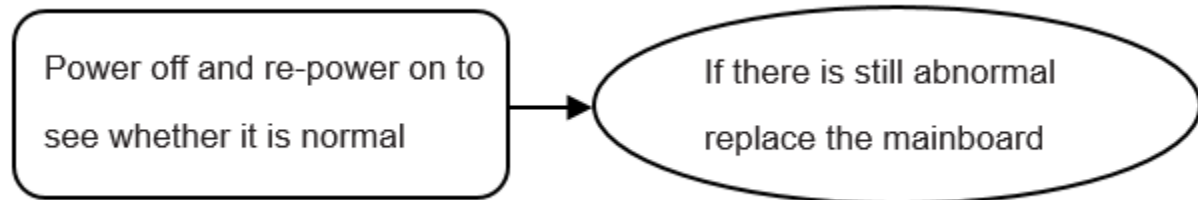

**P1/H2** ( High pressure switch protection )

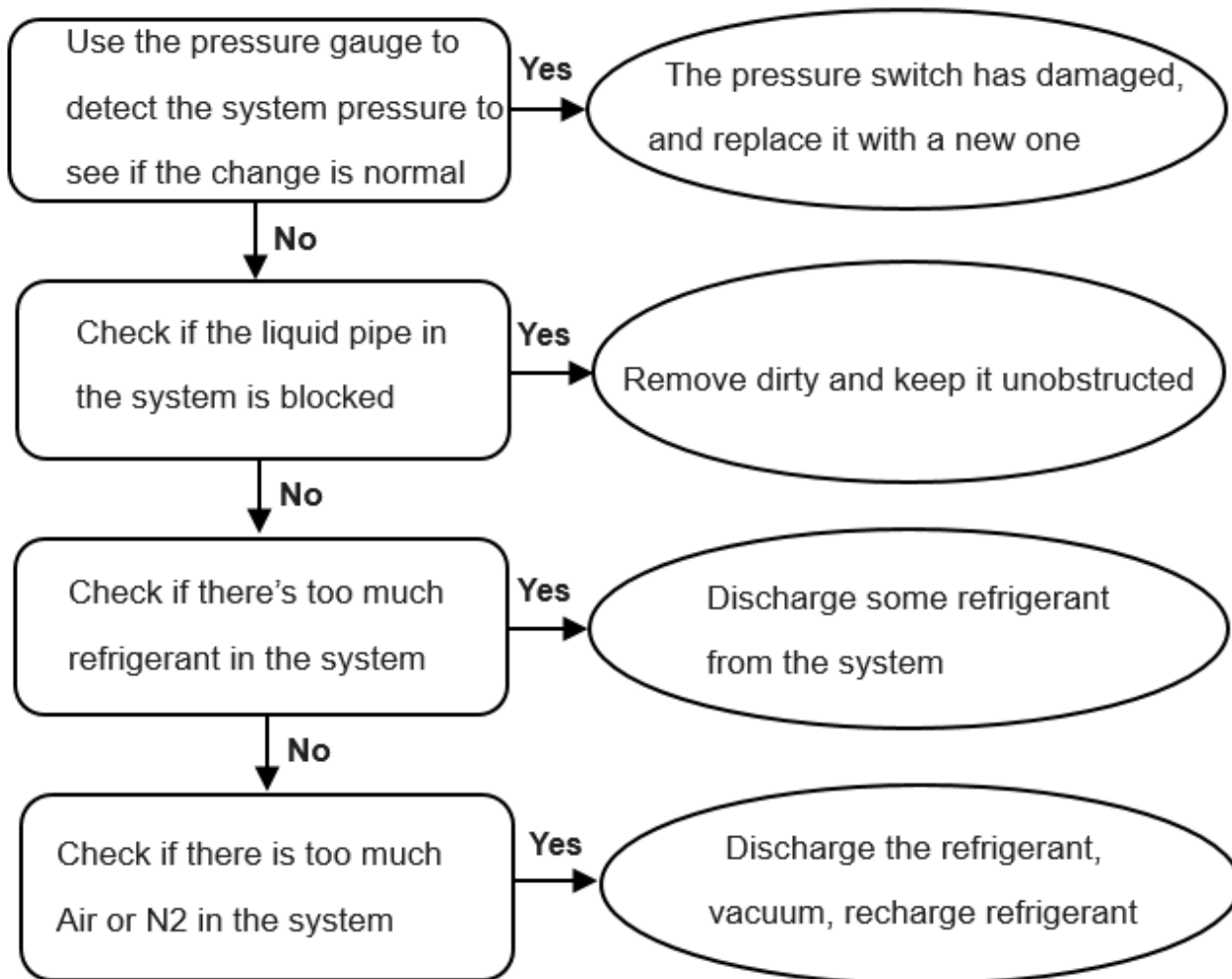

## Residential Split Troubleshooting (cont'd)

### P2/H5 (Low pressure switch protection)

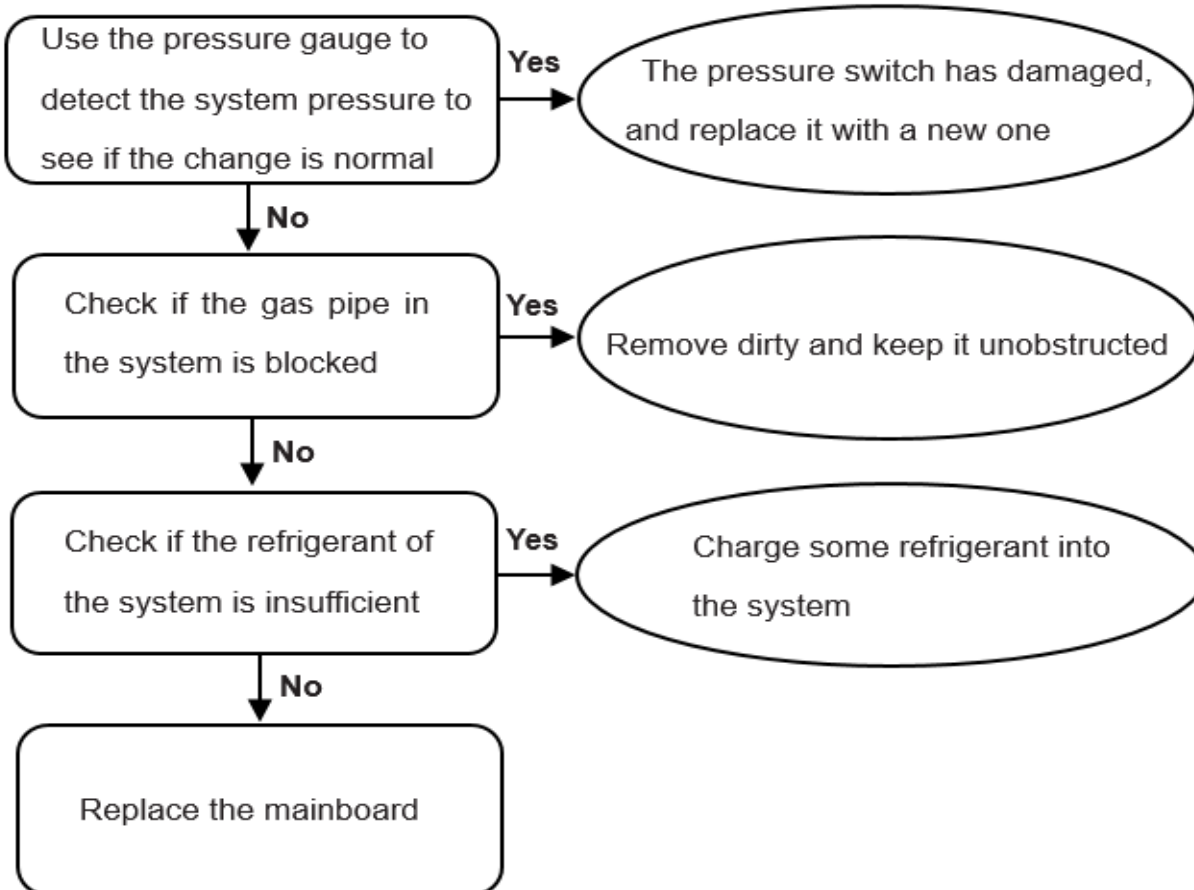

### P3 (Inverter over current protection)

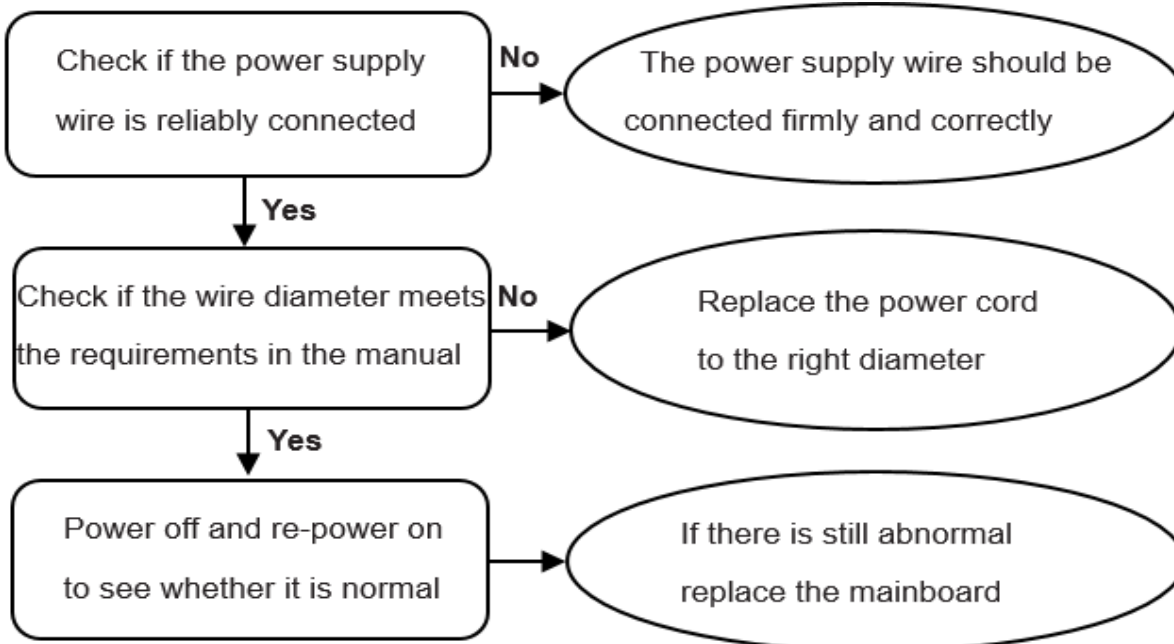

## Residential Split Troubleshooting (cont'd)

### P4/H6 (T5 Discharge temperature abnormal error)

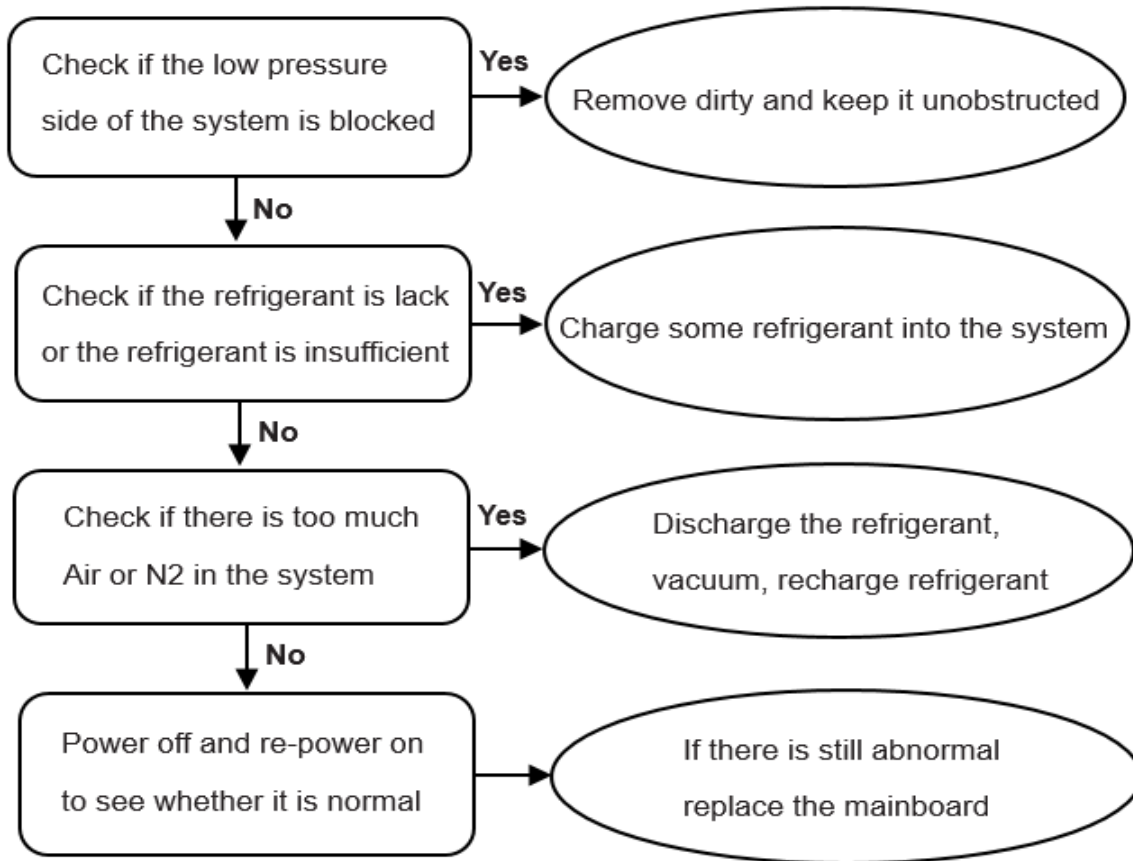

### P5/H1 (T3 condenser sensor high temp protection)

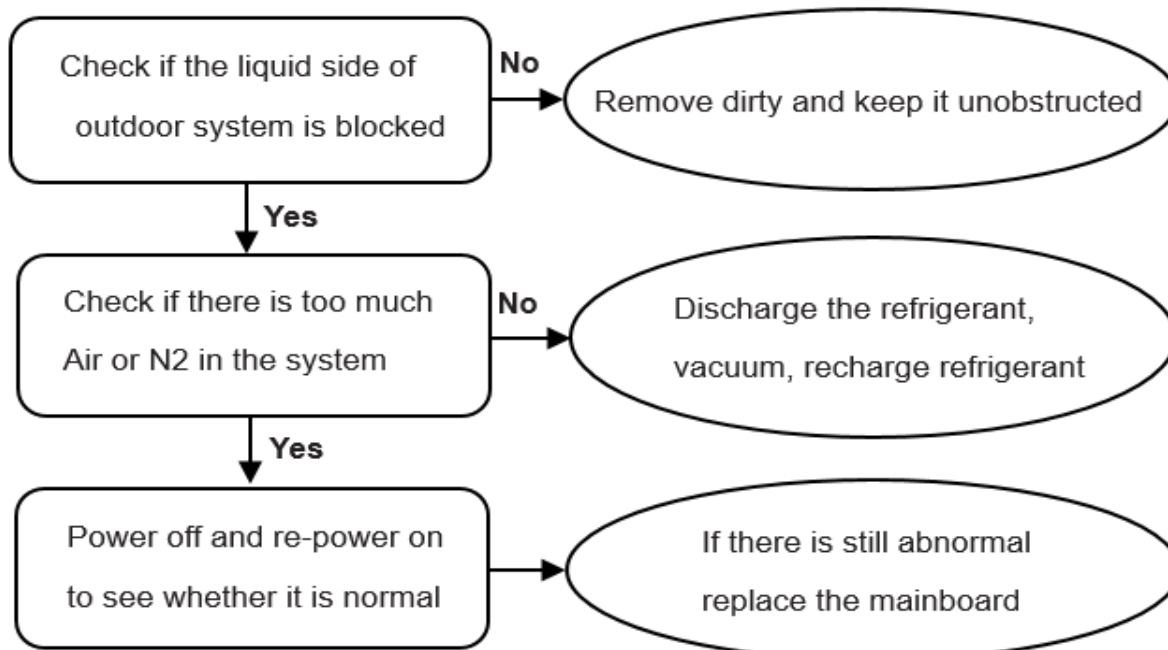

## Residential Split Troubleshooting (cont'd)

### P6 (IPM module protection)

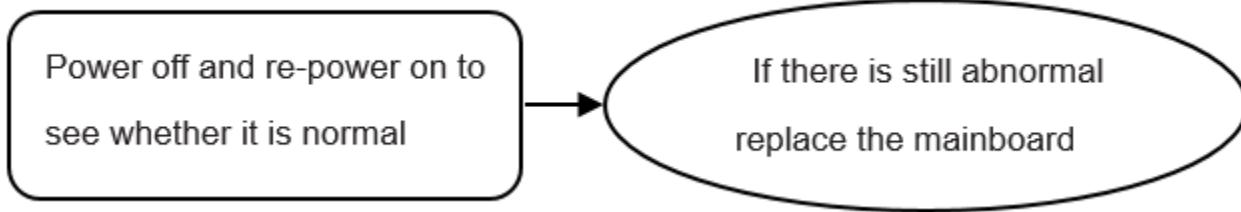

### P8/H4 (IPM high temperature protection)

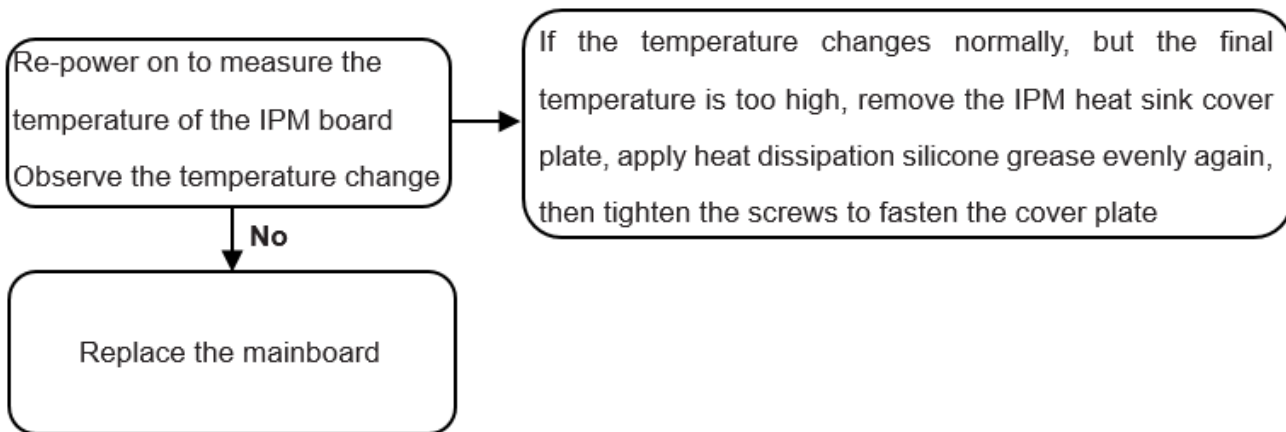

**IPM heat sink cover plate  
should be fastened**



## Residential Split Troubleshooting (cont'd)

### P9 (DC fan motor error)

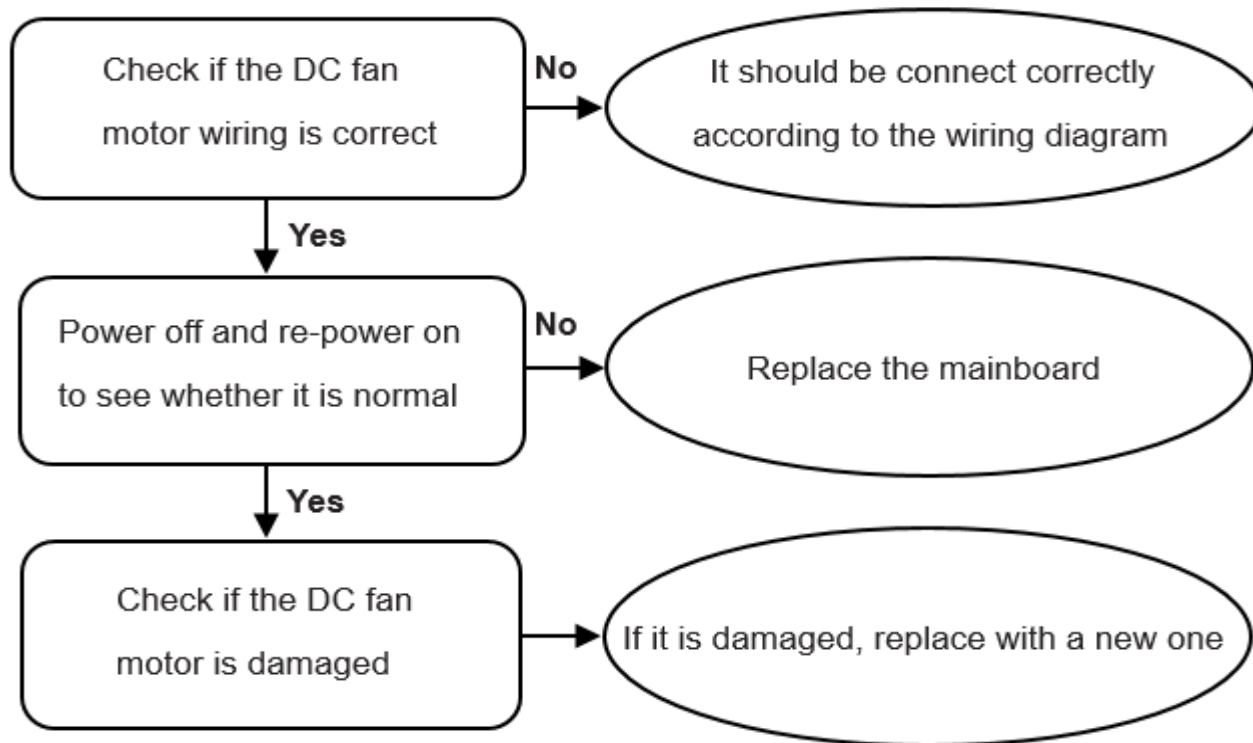

**The DC fan motor  
wire interface**

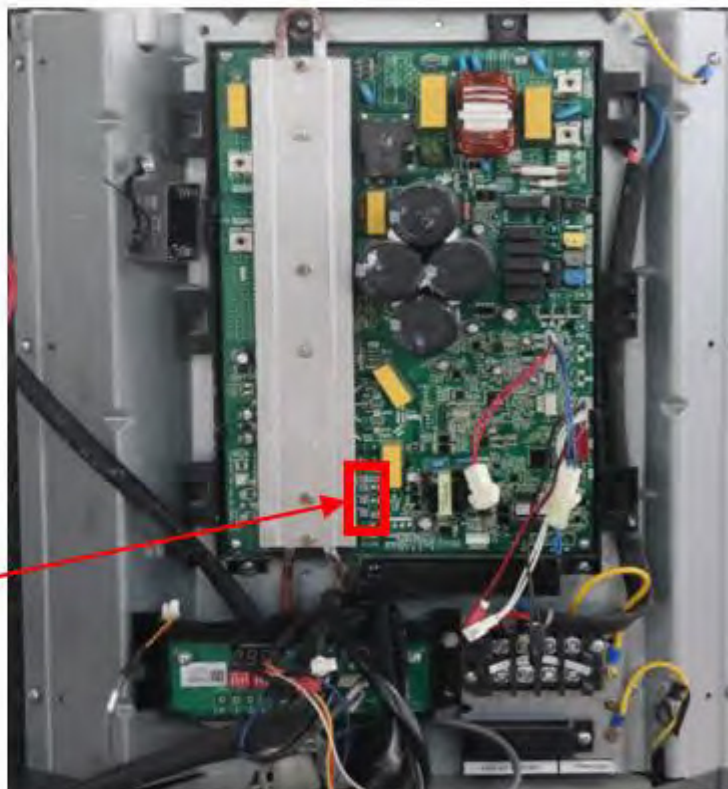

## Residential Split Troubleshooting (cont'd)

### P12/H7 (Wet operation error)

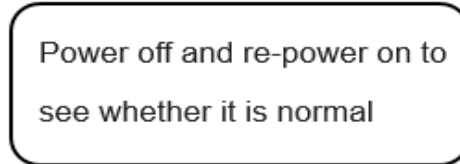

### P13/H3 (High pressure abnormal error-In heating mode)

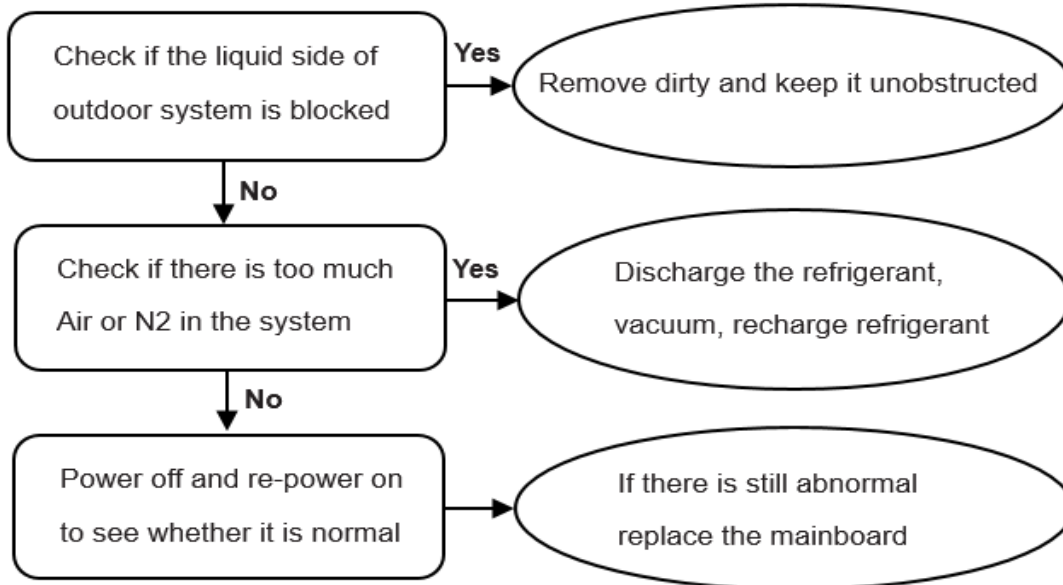

### P14 (High compression ratio protection)

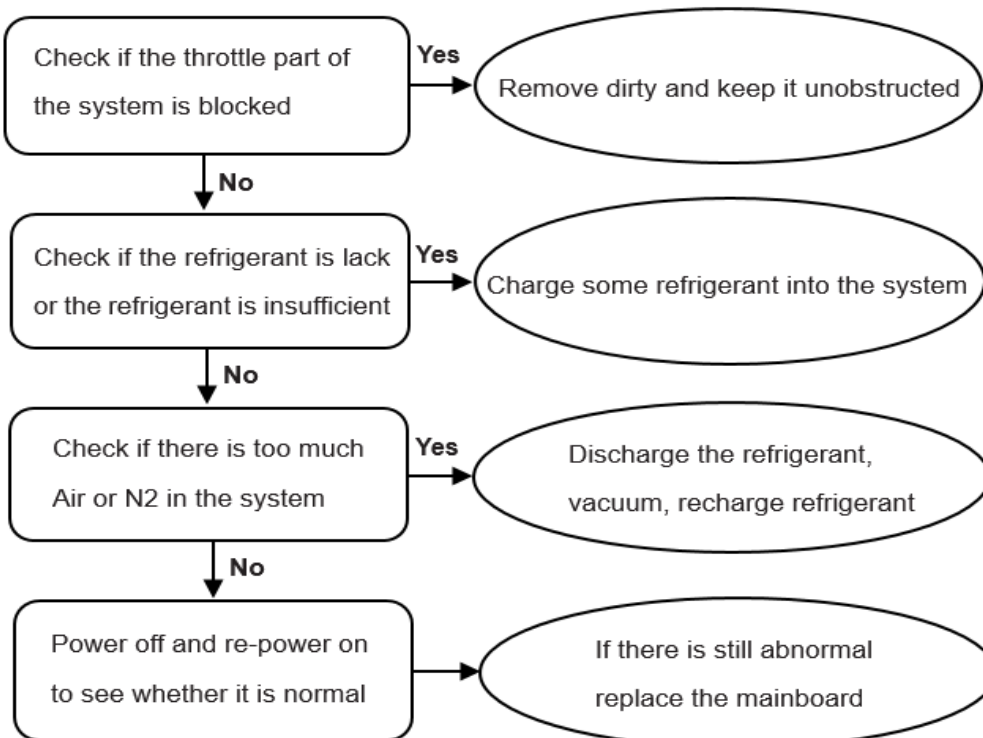

## Residential Split Troubleshooting (cont'd)

### P15 (Low compression ratio protection)

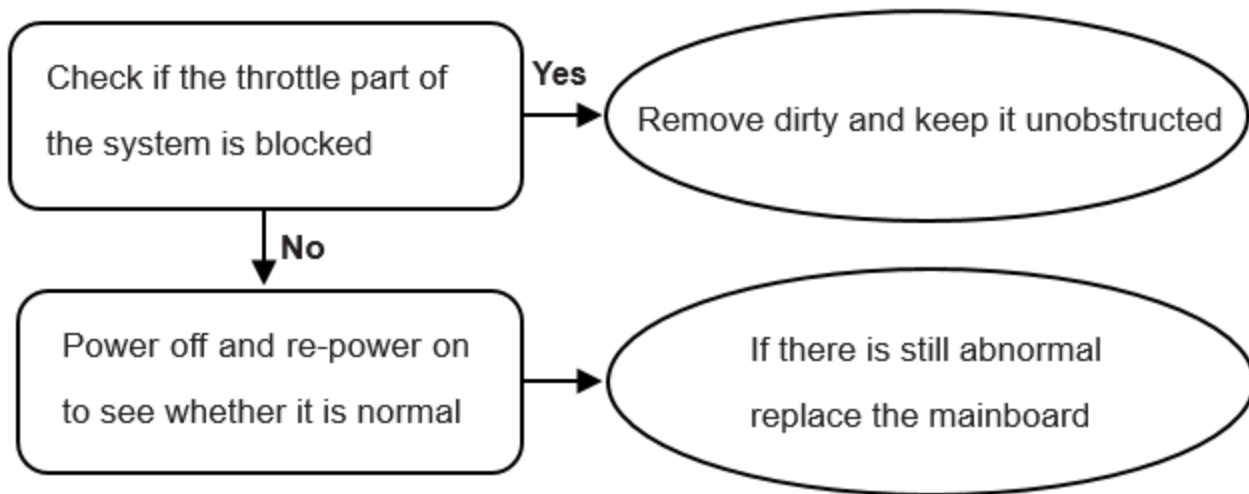

### L1/L2( DC cable bus low/high voltage protection)

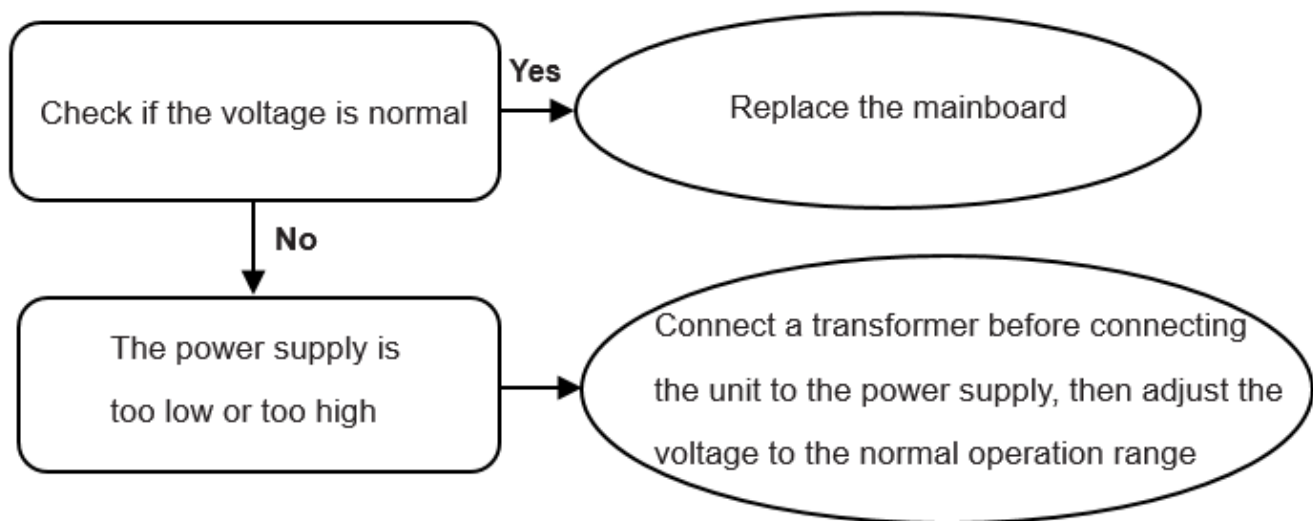

### L4-L8 (IPM module subdivision protection)

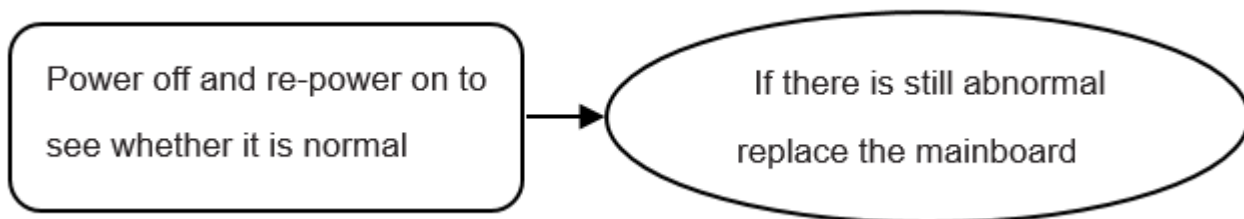

### L9-LE (Frequency limitation protection, not error)

**SEE IOM-0035 O/M APPENDICES MANUAL FOR MORE  
INFORMATION ON INSTALLATION AND SET UP OF  
PERIPHERAL DEVICES**



