



Solar HVAC 230V | Model "Z" 3-Ton Condensing Unit

Part Number

SHRDZ- 360*00A000 - **

Unit Type

D - Cooling Only

Voltage (*)

G - 230 VAC 1Φ
H - 230 VAC 3Φ

Options (**)

0 - No Options
D - Condenser Coil Coating (UG)
Y - Start Up
7 - Phase Monitor

Description

A Solar HVAC Residential Unit is more than twice as efficient as a standard residential split unit.

A solar box equipped with chambers lined with specialty reflective film is mounted to the top of the condensing unit. Through a patented process, ambient light is converted to thermal energy which reduces the energy demand on the compressor.

Units come with a 1-year parts warranty and 10 year compressor warranty.

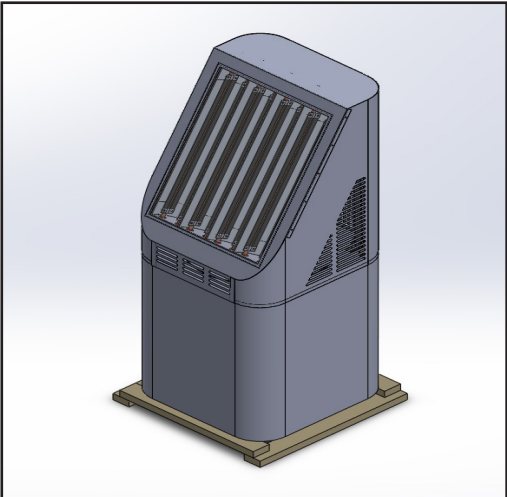



Dimensions

SHRDZ-36 | Solar HVAC Model "Z" Residential Condenser Dimensions

Model		SHRDZ-36 (3 Ton)	
Code	Outdoor Code		
Outdoor Power Supply	V/Hz	208-230V/60Hz	
Cooling	Capacity	Btu/h	34500
		W	2974
	EER	Btu/h, W	11.6
	SEER		17.5
Compressor	Type	Twin-rotary DC	
Outdoor Dimension	Packing (WxHxD)	Inch	32-5/8 x 32-5/8 x 71

(Outdoor Unit) Model		SHRDZ-36 (3 Ton)	
Outdoor Weight	Net - Lbs (kg)	257 (117)	
	*Gross - Lbs (kg)	262 (119)	
Electrical Data 208/230 1Φ	Minimum Circuit Ampacity	24.2 A	
	Max. Overcurrent Protection	40 A	
Electrical Data 208/230 3Φ	Minimum Circuit Ampacity	13.98 A	
	Max. Overcurrent Protection	20 A	
Outdoor Noise Level (dB(A))		78	
Operation Temperatures (°F)		5 - 118	

Note:
 Unit should be UL 1995 listed
 Unit should be OG-100 Certified to the Solar certification on ICC901/SRCC100
Note:
 Face solar panels south for optimal performance.

* Gross = Net Weight + Shipping Box

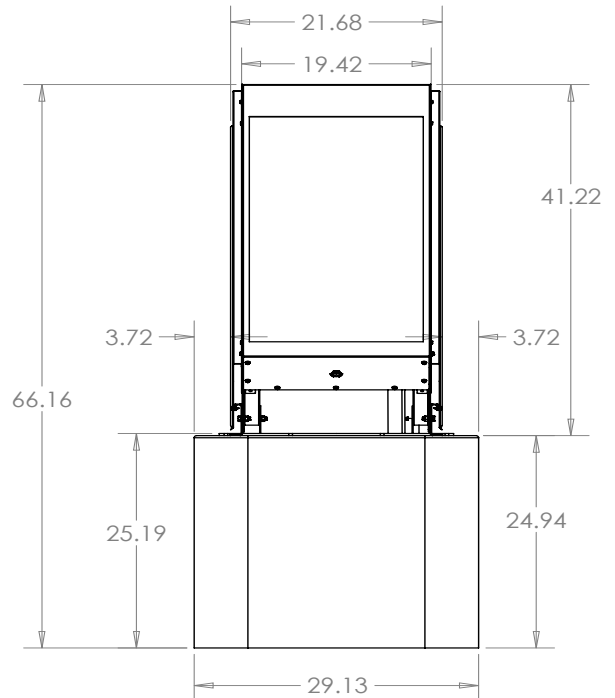
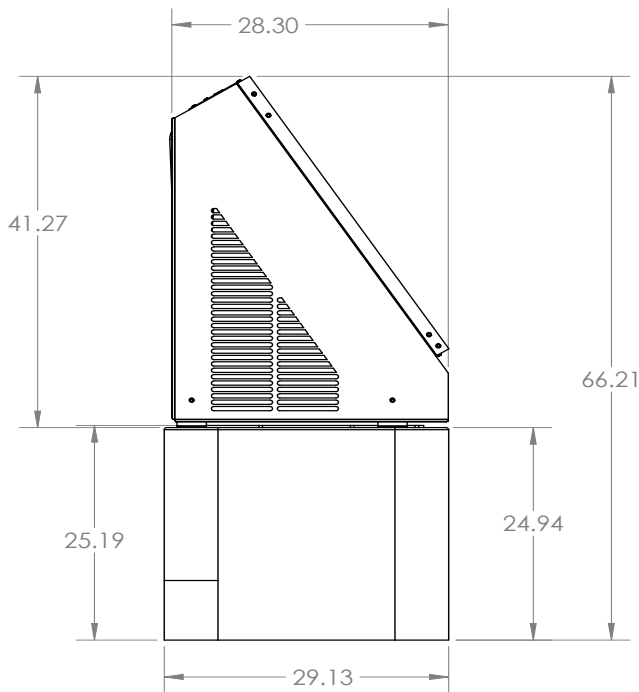

SHRDZ-36 | Solar HVAC Model "Z" Residential Condenser Clearances

SHR*-** Clearances | v 2.00 | 05/20/22

