



Solar HVAC 230V | Model "Z" 4-Ton ultra-Res Residential Unit

Part Number

SHRPZ- 48 L 5 67 8 910 11 - U\*

Unit Type	BTU's	Fan	Voltage (5)	Electric Heat (6,7)	Heat Stages (8)
P - Heat Pump	48 - 48,000 BTU's	L - Low/Std. Static	G - 230 VAC 1Φ H - 230 VAC 3Φ	00 - No Heat *05 - 5 kW *10 - 10 kW	A - No Controls *B - 1 Stage *M - Modulating

**Disconnect (9,10)**

- 00 - No Disconnect
- 01 - 240V - 30A Fuse
- 11 - 240V - 30A Switch

**Configuration (11)**

- \*A - Down Supply / Down Return
- \*D - Horizontal Supply / Horizontal Return

**Options (12)**

- 0 - No Options
- \*B - Whole Unit (UG)
- \*C - All Coils (UG)
- D - Condenser Coil (UG)
- \*K - DW w/ Poly Insulation
- \*N - Dirty Filter Switch
- U - Ultra Res
- Y - Start Up
- \*3 - Condensate Flow Switch
- 7 - Phase Monitor
- \*8 - Ionization Installed in AHU

\* - Only available when U - Ultra Res selected Options (12)

Description

A Solar HVAC Residential Unit is more than twice as efficient as a standard residential split unit.

A solar box equipped with chambers lined with specialty reflective film is mounted to the top of the condensing unit. Through a patented process, ambient light is converted to thermal energy which reduces the energy demand on the compressor.

ultraRES takes the highest efficiency condensing unit (made with the patented solar HVAC system) and pairs it with an air handling unit that comes equipped with a 4" filter box with a MERV 13 filter and VOC sensor. The 4" MERV 13 filter provides more than 4 times the filter efficiency of a standard 1" pleated filter. The VOC sensor is mounted in the space and provides the owner with feedback on how clean or dirty the air is inside the space.

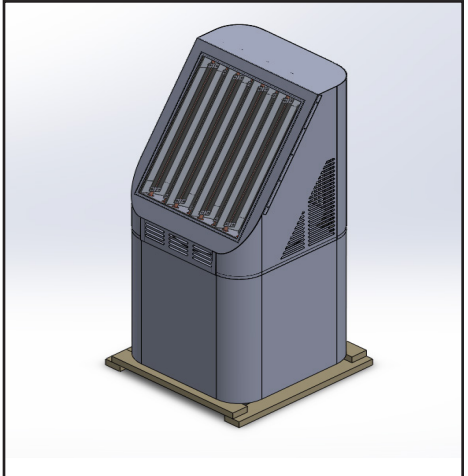

Units come with a 1-year parts warranty and 10 year compressor warranty.





# Dimensions

## SHRPZ-48 | Solar HVAC Model "Z" Residential Condenser Dimensions

Model		SHRPZ-48 (4 Ton)	
Code	Outdoor Code		
Outdoor Power Supply	V/Hz	208-230V/60Hz	
Cooling	Capacity	Btu/h	47000
		W	4692
	EER	Btu/h, W	11.6
	SEER		17.5
Heating	Capacity	Btu/h	46500
	COP	Btu/h.W	2.93
	HSPF		9.5
Compressor	Type	Twin-rotary DC	
Outdoor Dimension	Packing (WxHxD)	Inch	32-5/8 x 32-5/8 x 79-5/8

(Outdoor Unit) Model		SHRPZ-48 (4 Ton)	
Outdoor Weight	Net - Lbs (kg)	301 (137)	
	*Gross - Lbs (kg)	306 (139)	
Electrical Data 208/230 1Φ	Minimum Circuit Ampacity	31.9 A	
	Max. Overcurrent Protection	50 A	
Electrical Data 208/230 3Φ	Minimum Circuit Ampacity	18.43 A	
	Max. Overcurrent Protection	20 A	
Outdoor Noise Level (dB(A))		79	
Operation Temperatures (°F)		5 - 118	

\* Gross = Net Weight + Shipping Box

**Note:** Calculated E COP value with solar panel: 3.63

**Note:**  
Unit should be UL 1995 listed  
Unit should be OG-100 Certified to the Solar certification on ICC901/SRCC100

**Note:**  
Face solar panels south for optimal performance.

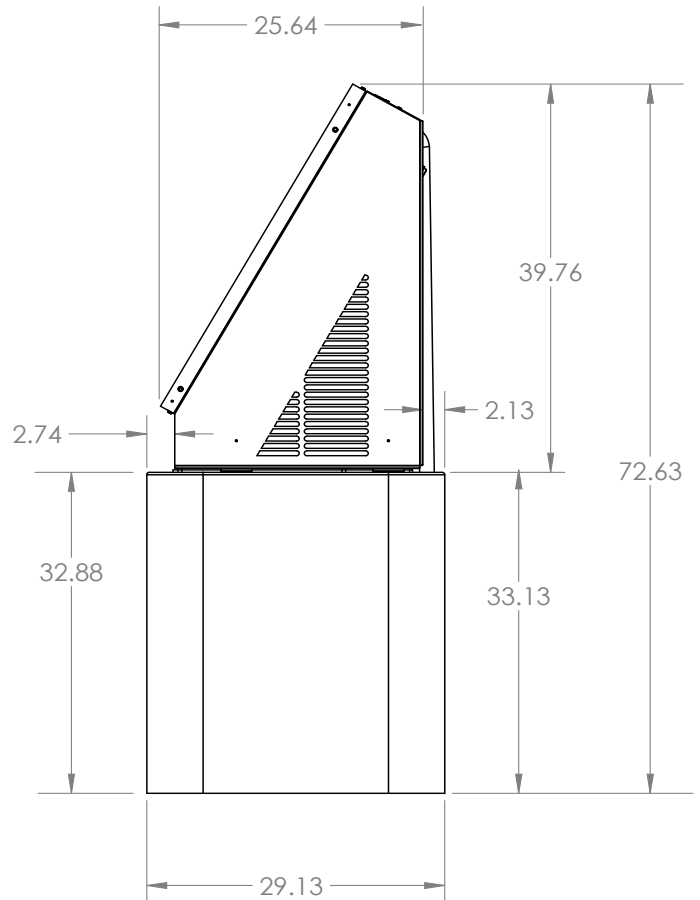
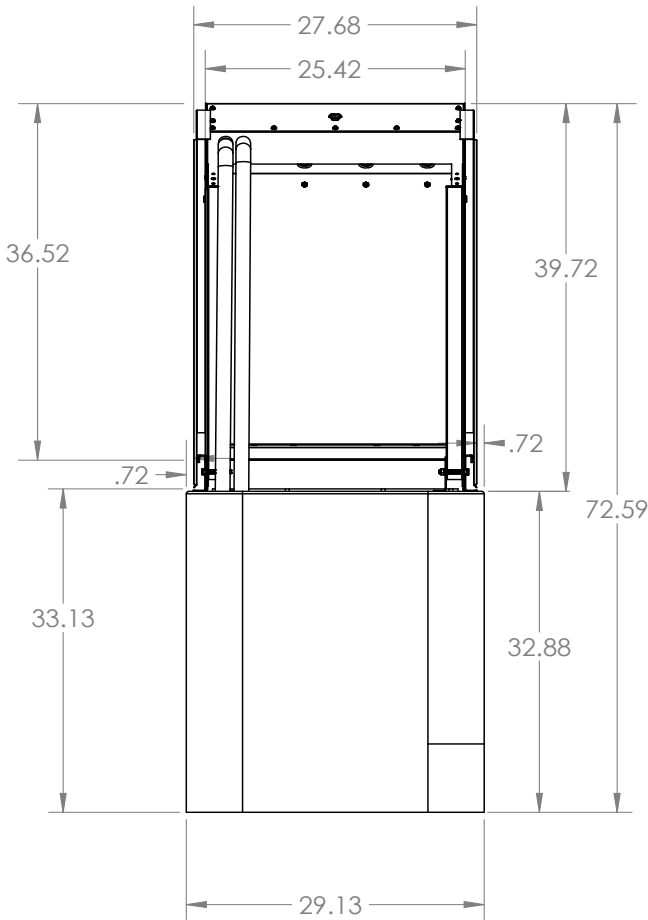

**SHRPZ-48 | Solar HVAC Model "Z" Residential Condenser Clearances**

SHR\*-\*\* Clearances | v 2.00 | 03/13/23

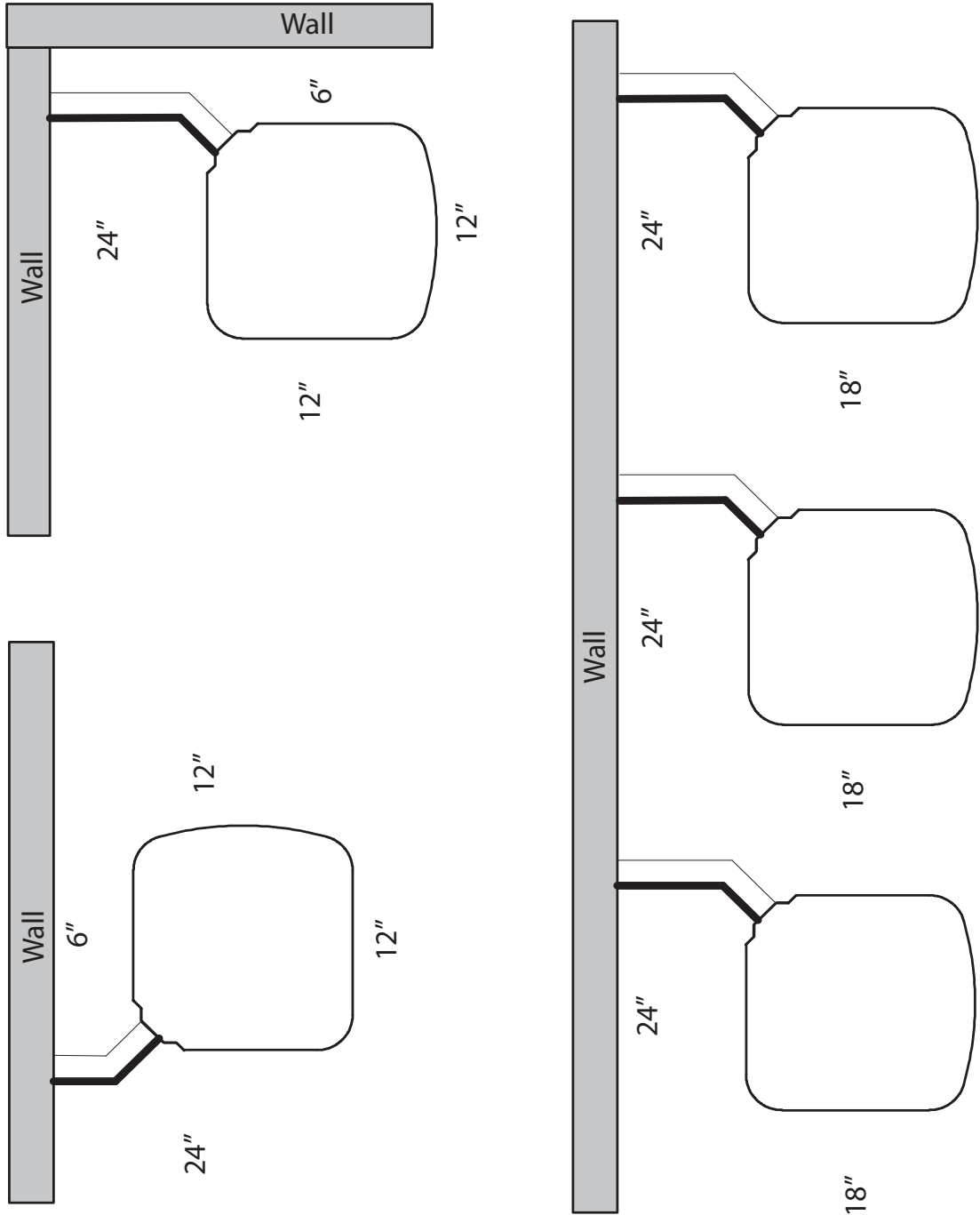

\* - Unit Type (Cooling Only (D) or Heat Pump (P))  
 \*\* - BTU's - x 1000 (24, 36, 48, 60)



# Specifications and Dimensions

## SHRPZ-48-FV4 | Solar HVAC Model "Z" Residential AHU Dimensions

Evap Coil Specs.	Face Area	Puron Refrigerant	Filter In. (mm)	Motor Type	Motor HP	CFM
	5.93 sq. ft.	TXV	19-7/8" (505 mm)	ECM	1/2	1260

Nominal Cooling Capacity	Shipping Weight
48,000	172 lbs / 78 kg

### Estimated Sound Power Level (dBA)

Conditions		Octave Band Center Frequency						
CFM	Ext. Static Pressure	63	125	250	500	1000	2000	4000
1200	0.25	68	62	60	57	55	53	49

### Electrical Data for Units Without Electrical Heat

Motor HP	MTR FLA	Volts/Ph/Hz	Single Circuit		Min. Wire Size
			MCA	Max. Overcurrent	
3/4	6.8	208/230/1/60	8.5	15	14 AWG

UNIT #	A	B	C	D	E	H	J
FV4048	53-7/16	21-1/8	19-1/4	19-1/8	19-3/16	28-5/16	—

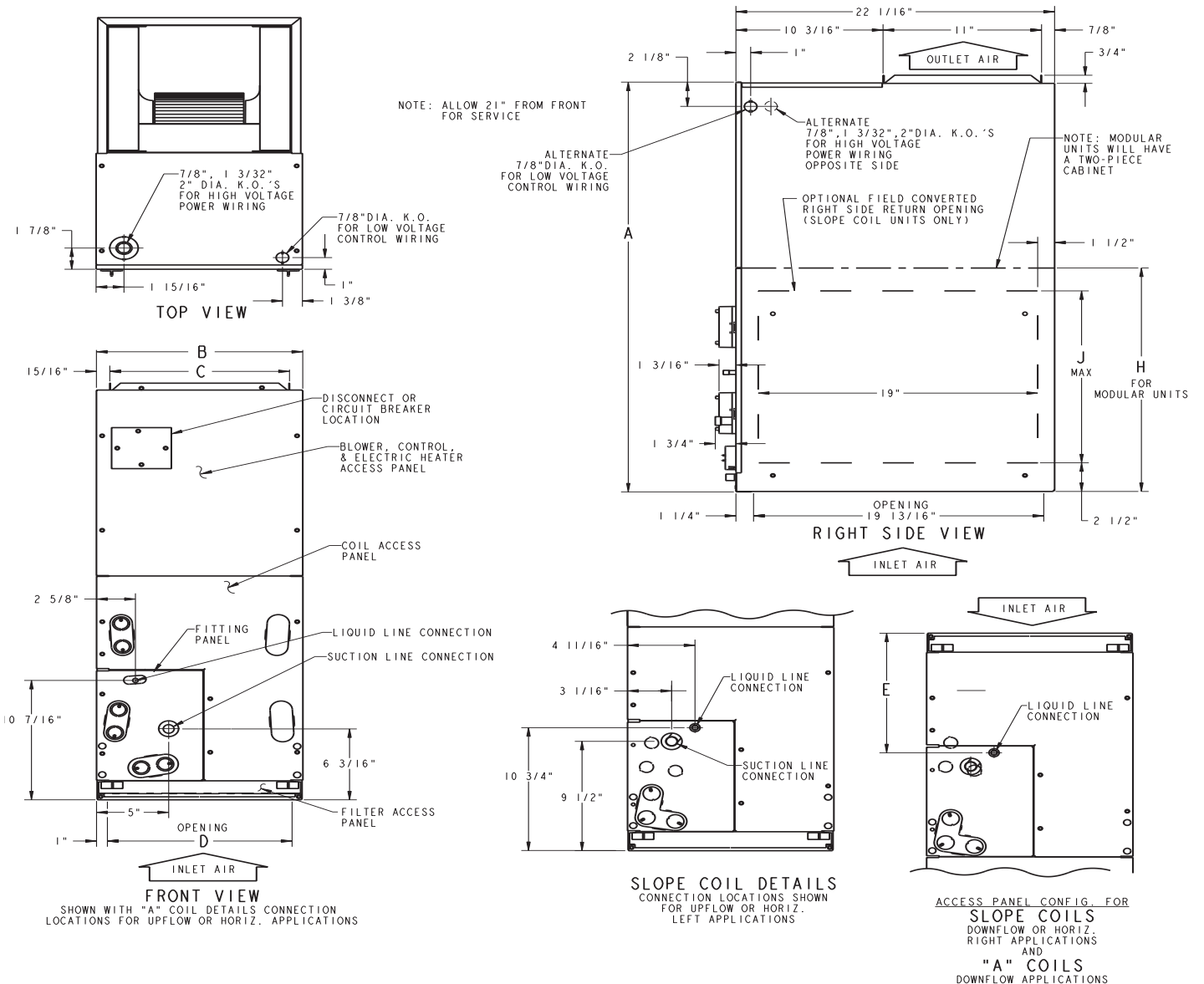

**SHRPZ-48-FV4 | Solar HVAC Model "Z" Residential AHU Clearances**

SHR\*-FV4 AHU Clearances | v 1.00 | 03/13/23

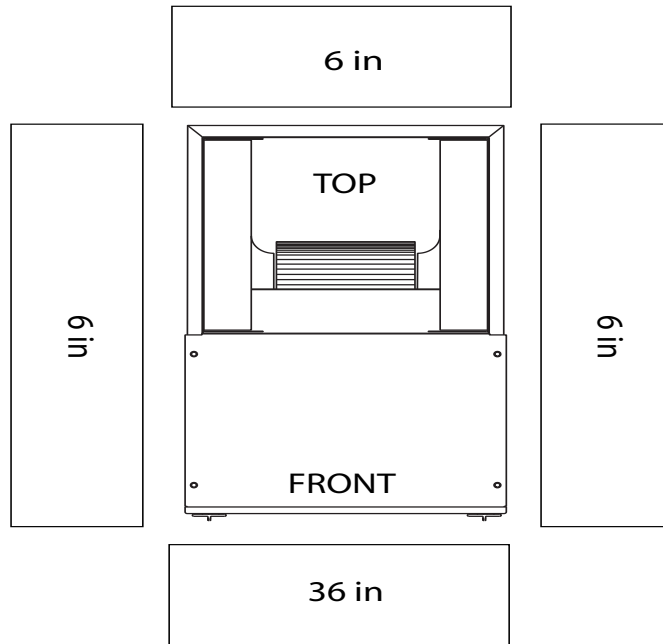

**OPTIONAL ELECTRIC HEAT CLEARANCES**

