



Solar HVAC 230V | Model "Z" 4-Ton FV4C Residential Unit

Part Number

SHRDZ- 48 L 5 67 8 910 11 - F*

Unit Type	BTU's	Fan	Voltage (5)	Electric Heat (6,7)	Heat Stages (8)
D - Cooling Only	48 - 48,000 BTU's	L - Low/Std. Static	G - 230 VAC 1Φ H - 230VAC 3Φ	00 - No Heat *05 - 5 kW *10 - 10 kW	A - No Controls *B - 1 Stage *M - Modulating

Disconnect (9,10)

- 00 - No Disconnect
- 01 - 240V - 30A Fuse
- 11 - 240V - 30A Switch

Configuration (11)

- 0 - Condenser Only
- *A - Down Supply / Down Return
- *D - Horizontal Supply / Horizontal Return

Options (12)

- 0 - No Options
- *B - Whole Unit (UG)
- *C - All Coils (UG)
- D - Condenser Coil (UG)
- F - FV4C AHU
- *K - DW w/ Poly Insulation
- *N - Dirty Filter Switch
- Y - Start Up
- *3 - Condensate Flow Switch
- 7 - Phase Monitor
- *8 - Ionization Installed in AHU

* - Only available when F - FV4C AHU selected in Options (12)

Description

A Solar HVAC Residential Unit is more than twice as efficient as a standard residential split unit.

A solar box equipped with chambers lined with specialty reflective film is mounted to the top of the condensing unit. Through a patented process, ambient light is converted to thermal energy which reduces the energy demand on the compressor.

The highest efficiency condensing unit (made with the patented solar HVAC system) is paired with an FV4C air handling unit that comes equipped with a standard 1" pleated filter.

Units come with a 1-year parts warranty and 10 year compressor warranty.

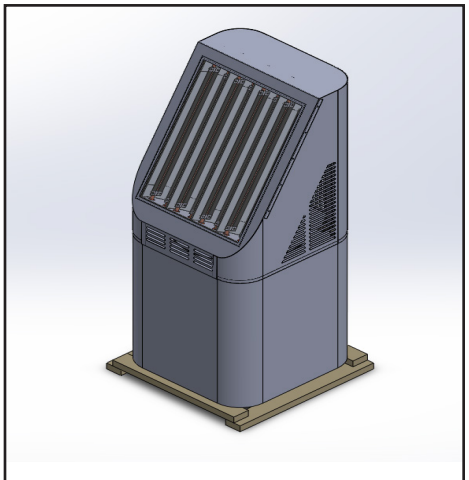



Dimensions

SHRDZ-48 | Solar HVAC Model "Z" Residential Condenser Dimensions

Model		SHRDZ-48 (4 Ton)	
Code	Outdoor Code		
Outdoor Power Supply	V/Hz	208-230V/60Hz	
Cooling	Capacity	Btu/h	47000
		W	4692
	EER	Btu/h, W	11.6
	SEER		17.5
Compressor	Type	Twin-rotary DC	
Outdoor Dimension	Packing (WxHxD)	Inch	32-5/8 x 32-5/8 x 79-5/8

(Outdoor Unit) Model		SHRDZ-48 (4 Ton)	
Outdoor Weight	Net - Lbs (kg)	301 (137)	
	*Gross - Lbs (kg)	306 (139)	
Electrical Data 208/230 1Φ	Minimum Circuit Ampacity	31.9 A	
	Max. Overcurrent Protection	50 A	
Electrical Data 208/230 3Φ	Minimum Circuit Ampacity	18.43 A	
	Max. Overcurrent Protection	20 A	
Outdoor Noise Level (dB(A))		79	
Operation Temperatures (°F)		5 - 118	

Note:
 Unit should be UL 1995 listed
 Unit should be OG-100 Certified to the Solar certification on ICC901/SRCC100
Note: Face solar panels south for optimal performance.

* Gross = Net Weight + Shipping Box

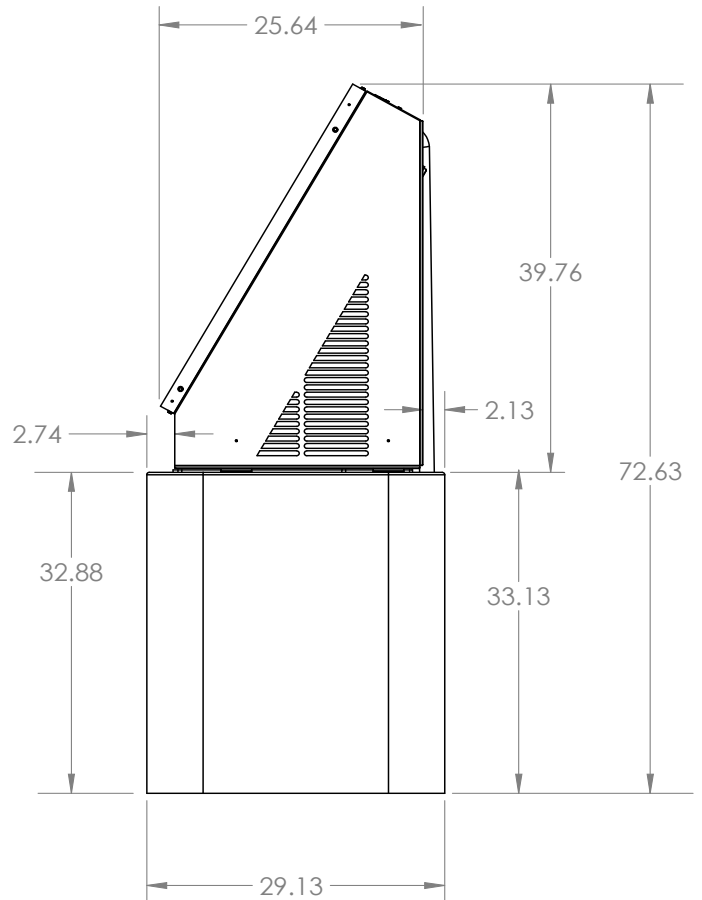
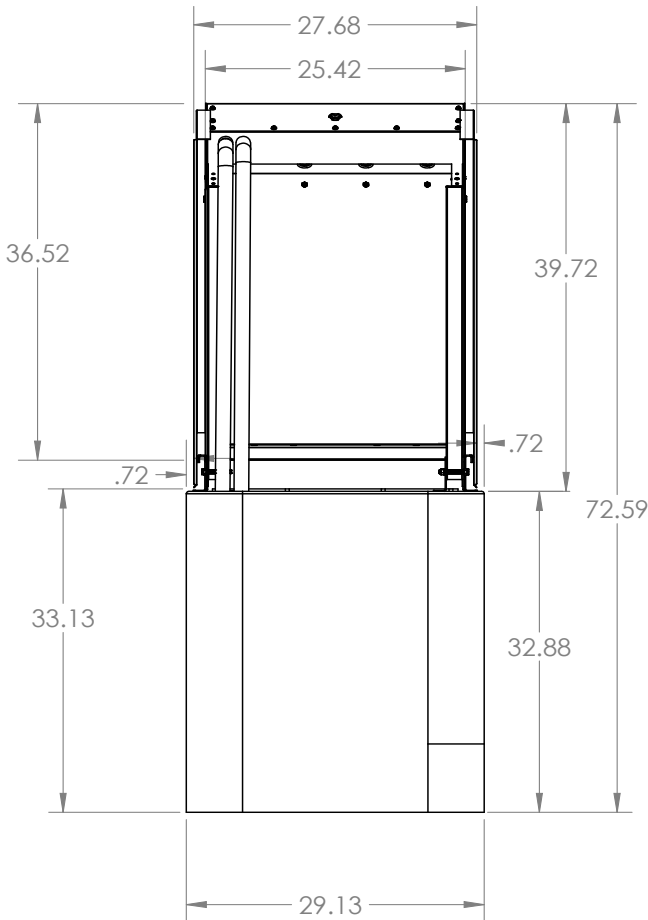

SHR*-** Clearances | v 2.00 | 03/13/23

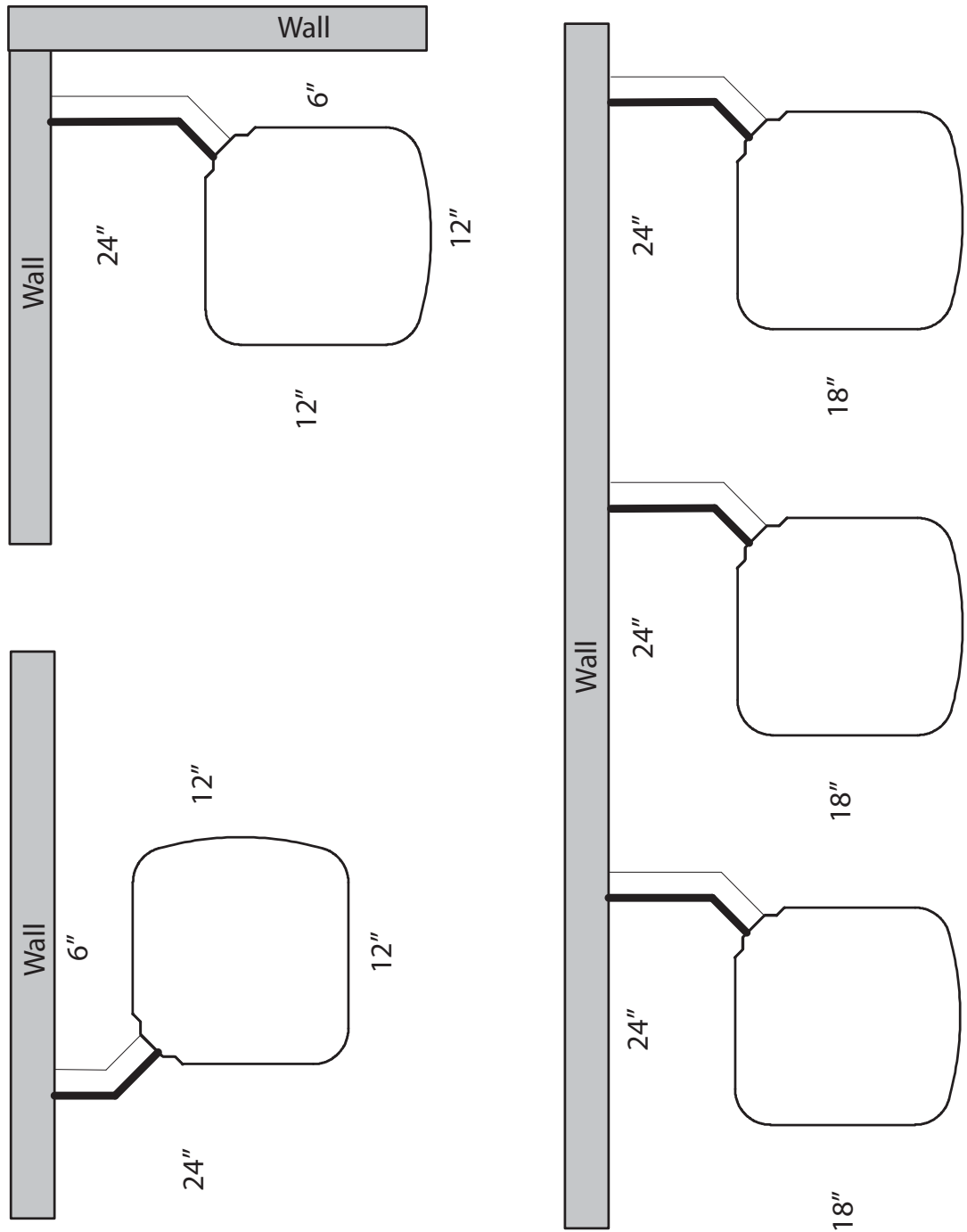

* - Unit Type (Cooling Only (D) or Heat Pump (P))

** - BTU's - x 1000 (24, 36, 48, 60)



Specifications and Dimensions

SHRDZ-48-FV4 | Solar HVAC model "Z" Residential FV4C AHU Dimensions

Evap Coil Specs.	Face Area	Puron Refrigerant	Filter In. (mm)	Motor Type	Motor HP	CFM
	5.93 sq. ft.	TXV	19-7/8" (505 mm)	ECM	1/2	1260

Nominal Cooling Capacity	Shipping Weight
48,000	172 lbs / 78 kg

Estimated Sound Power Level (dBA)

Conditions		Octave Band Center Frequency						
CFM	Ext. Static Pressure	63	125	250	500	1000	2000	4000
1200	0.25	68	62	60	57	55	53	49

Electrical Data for Units Without Electrical Heat

Motor HP	MTR FLA	Volts/Ph/Hz	Single Circuit		Min. Wire Size
			MCA	Max. Overcurrent	
3/4	6.8	208/230/1/60	8.5	15	14 AWG

UNIT #	A	B	C	D	E	H	J
FV4048	53-7/16	21-1/8	19-1/4	19-1/8	19-3/16	28-5/16	—

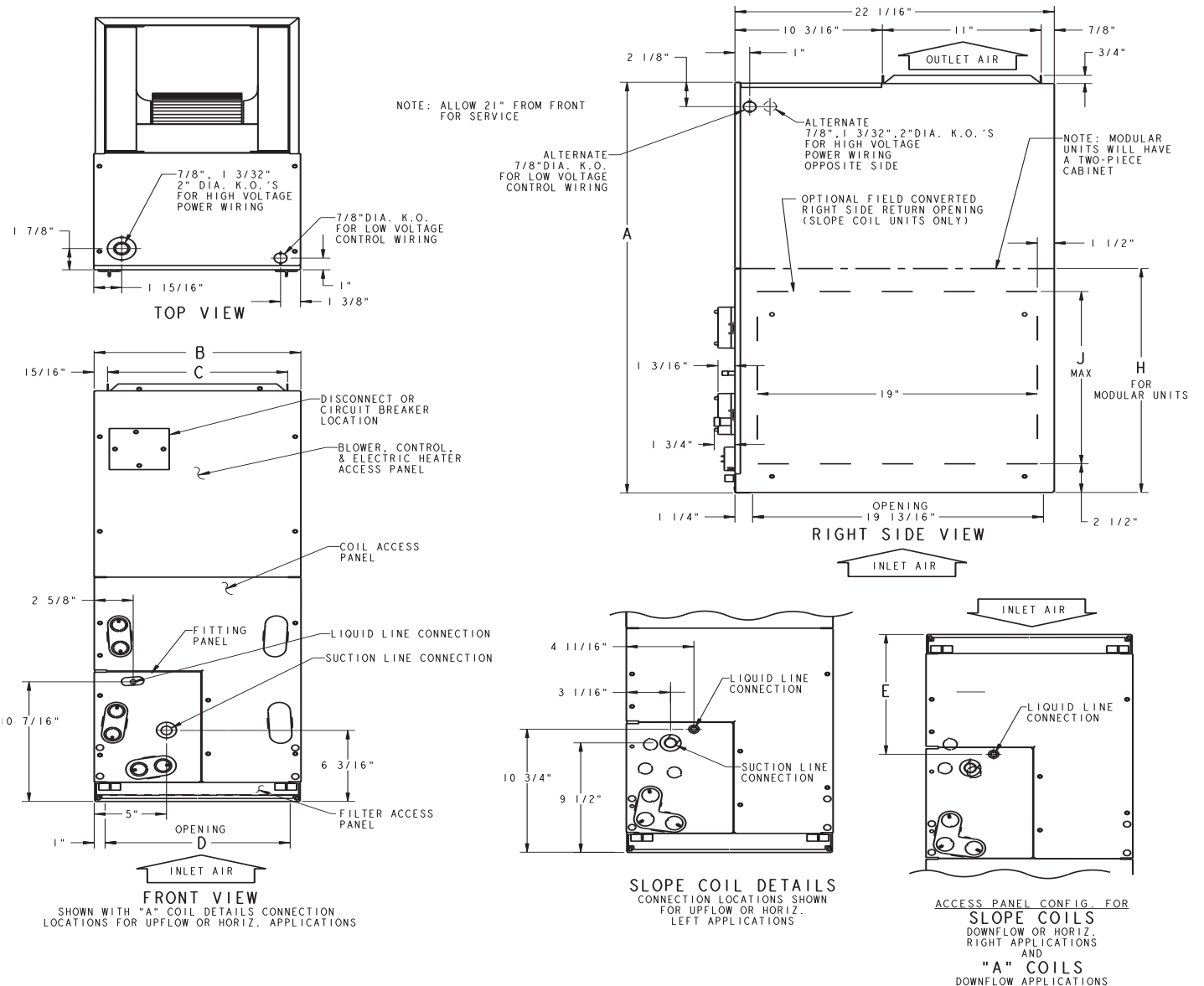

SHRDZ-48-FV4 | Solar HVAC Model "Z" Residential FV4C AHU Clearances

SHR*-FV4 AHU Clearances | v 1.00 | 03/13/23

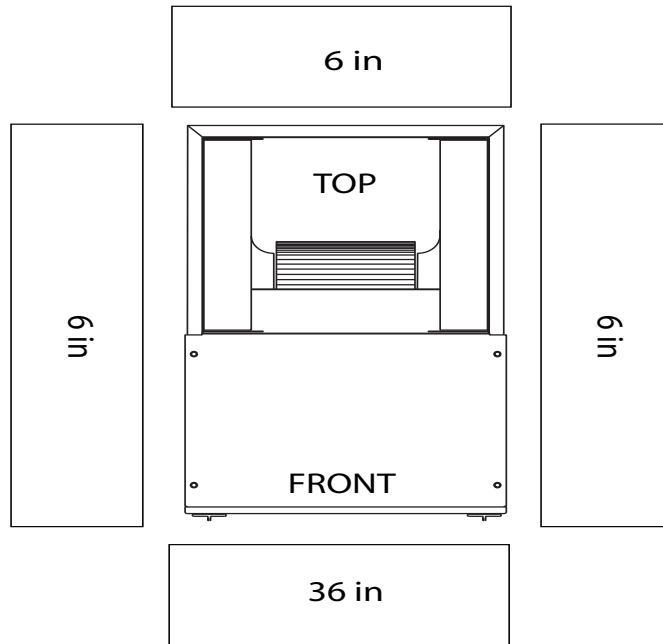

OPTIONAL ELECTRIC HEAT CLEARANCES

