



Solar HVAC 230V | Model "Z" 2-Ton Residential Unit

Part Number

SHRPZ- 24 L 5 67 8 910 11 - A*

Unit Type	BTU's	Fan	Voltage (5)	Electric Heat (6,7)	Heat Stages (8)
P - Heat Pump	24 - 24,000 BTU's	L - Low/Std. Static	G - 230 VAC 1Φ H - 230 VAC 3Φ	00 - No Heat *05 - 5 kW *10 - 10 kW	A - No Controls *B - 1 Stage *M - Modulating

Disconnect (9,10)
00 - No Disconnect 01 - 240V - 30A Fuse 11 - 240V - 30A Switch

Configuration (11)
*A - Down Supply / Down Return *D - Horizontal Supply / Horizontal Return

Options (12)
0 - No Options A - Model Z AHU *B - Whole Unit (UG) *C - All Coils (UG) D - Condenser Coil (UG) *K - DW w/ Poly Insulation *N - Dirty Filter Switch Y - Start Up *3 - Condensate Flow Switch 7 - Phase Monitor *8 - Ionization Installed in AHU

* - Only available when A - Model Z AHU selected Options (12)

Description

A Solar HVAC Residential Unit is more than twice as efficient as a standard residential split unit.

A solar box equipped with chambers lined with specialty reflective film is mounted to the top of the condensing unit. Through a patented process, ambient light is converted to thermal energy which reduces the energy demand on the compressor.

The highest efficiency condensing unit (made with the patented solar HVAC system) is paired with a Model "Z" air handling unit that comes equipped with a standard 1" pleated filter.

Units come with a 1-year parts warranty and 10 year compressor warranty.

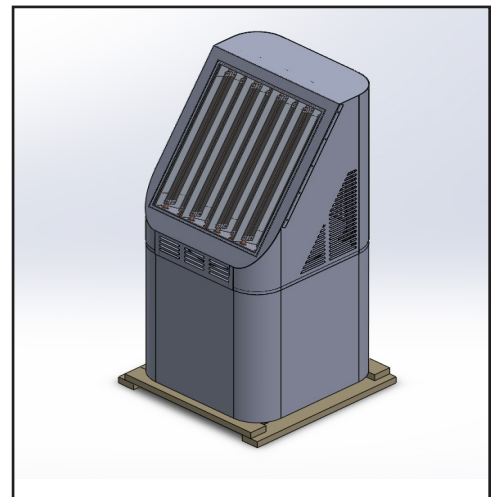



Dimensions

SHRPZ-24 | Solar HVAC Model "Z" Residential Condenser Dimensions

Model		SHRPZ-24 (2 Ton)	
Code	Outdoor Code		
Outdoor Power Supply	V/Hz	208-230V/60Hz	
Cooling	Capacity	Btu/h	24000
		W	1920
	EER	Btu/h, W	12.5
	SEER		17.5
Heating	Capacity	Btu/h	24000
	COP	Btu/h.W	3.66
	HSPF		9.5
Compressor	Type	Twin-rotary DC	
Outdoor Dimension	Packing (WxHxD)	Inch	32-5/8 x 32-5/8 x 71

(Outdoor Unit) Model		SHRPZ-24 (2 Ton)	
Outdoor Weight	Net - Lbs (kg)	257 (117)	
	*Gross - Lbs (kg)	262 (119)	
Electrical Data 208/230 1φ	Minimum Circuit Ampacity	17.7 A	
	Max. Overcurrent Protection	30 A	
Electrical Data 208/230 3φ	Minimum Circuit Ampacity	10.23 A	
	Max. Overcurrent Protection	20 A	
Outdoor Noise Level (dB(A))		78	
Operation Temperatures (°F)		5 - 118	

* Gross = Net Weight + Shipping Box

Note: Calculated E COP value with solar panel: 4.60

Note:
Unit should be UL 1995 listed
Unit should be OG-100 Certified to the Solar certification on ICC901/SRCC100

Note:
Face solar panels south for optimal performance.

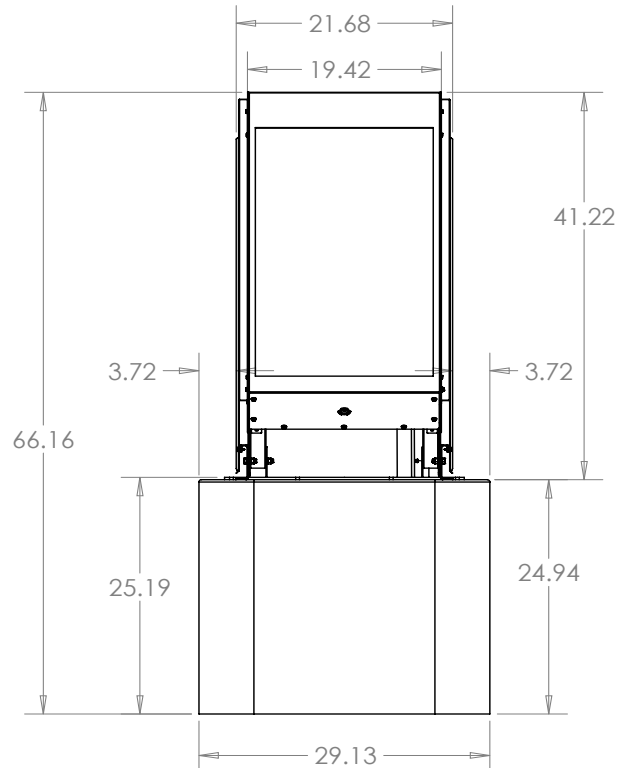
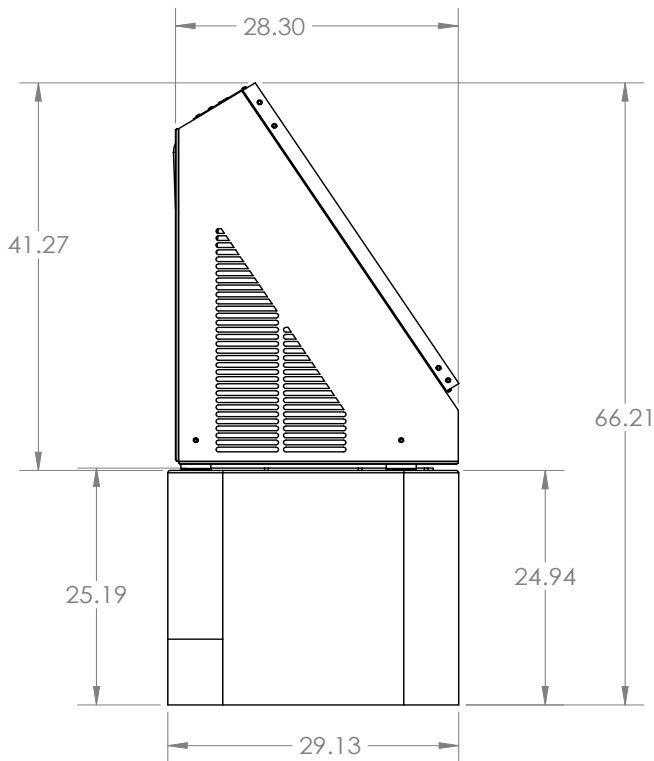

SHRDZ-24 | Solar HVAC Model "Z" Residential Condenser Clearances

SHR*-** Clearances | v 2.00 | 05/20/22

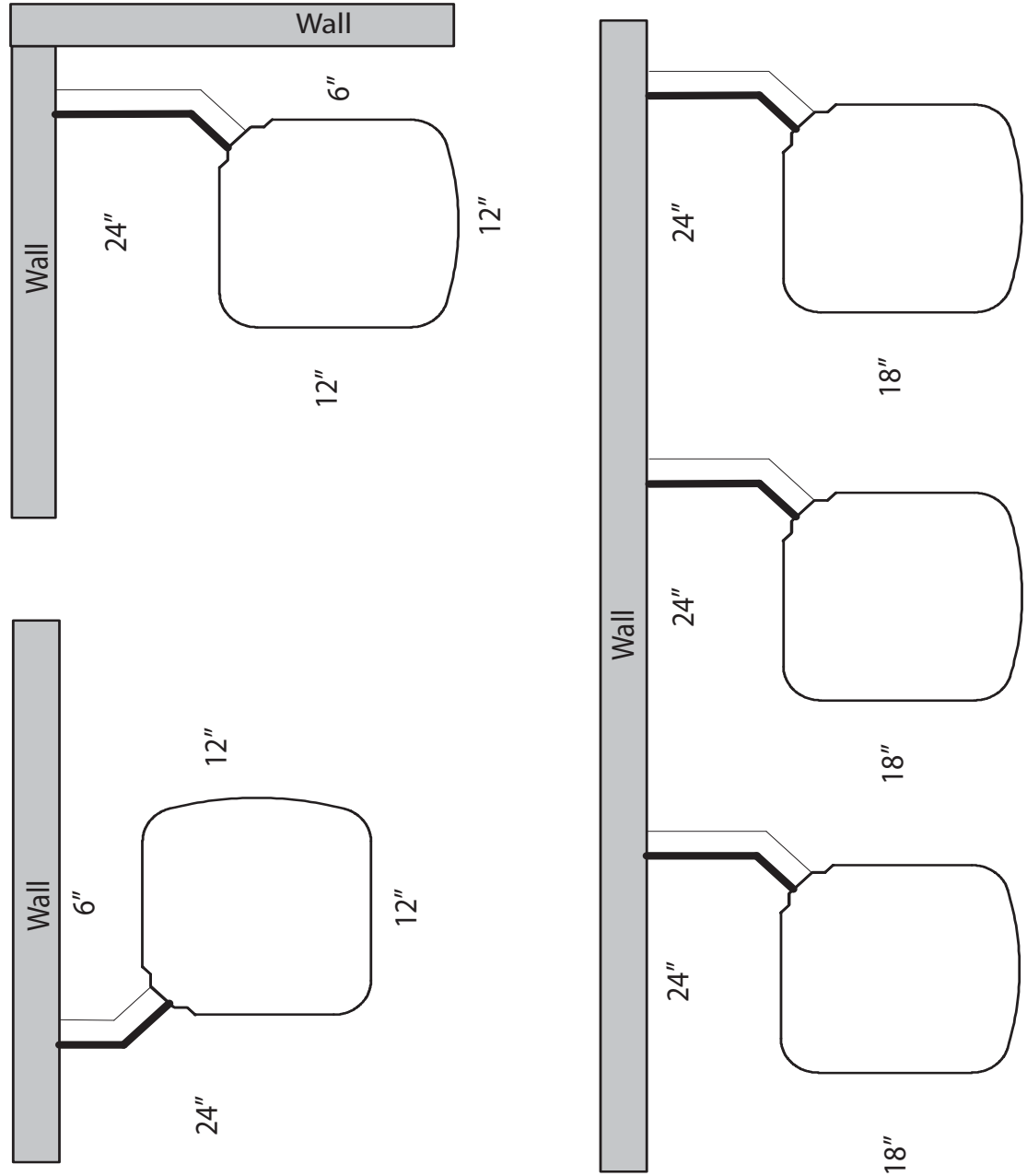

* - Unit Type (Cooling Only (D) or Heat Pump (P))
 ** - BTU's - x 1000 (24, 36, 48, 60)



Specifications and Dimensions

SHRDZ-24-ZERO | Solar HVAC Model "Z" Residential AHU Dimensions

Evap Coil Specs.	Type	Puron Refrigerant	Nominal Cooling Capacity	CFM	Ext. Static Pressure	Indoor Noise Level
	Inner Groove	TXV	24,000	780	0.10	63

Motor Type	Motor HP	Motor RPM	Motor FLA	V/Ph/Hz	MCA	MOCP
ECM	1/3	1050	2.8	208-230/1/60	1.7	22

Shipping Weight	Shipping Dimensions
126/139 lbs	22.83 x 47.64 x 25.59 in.
57/63 kg	580 x 1210 x 650 mm

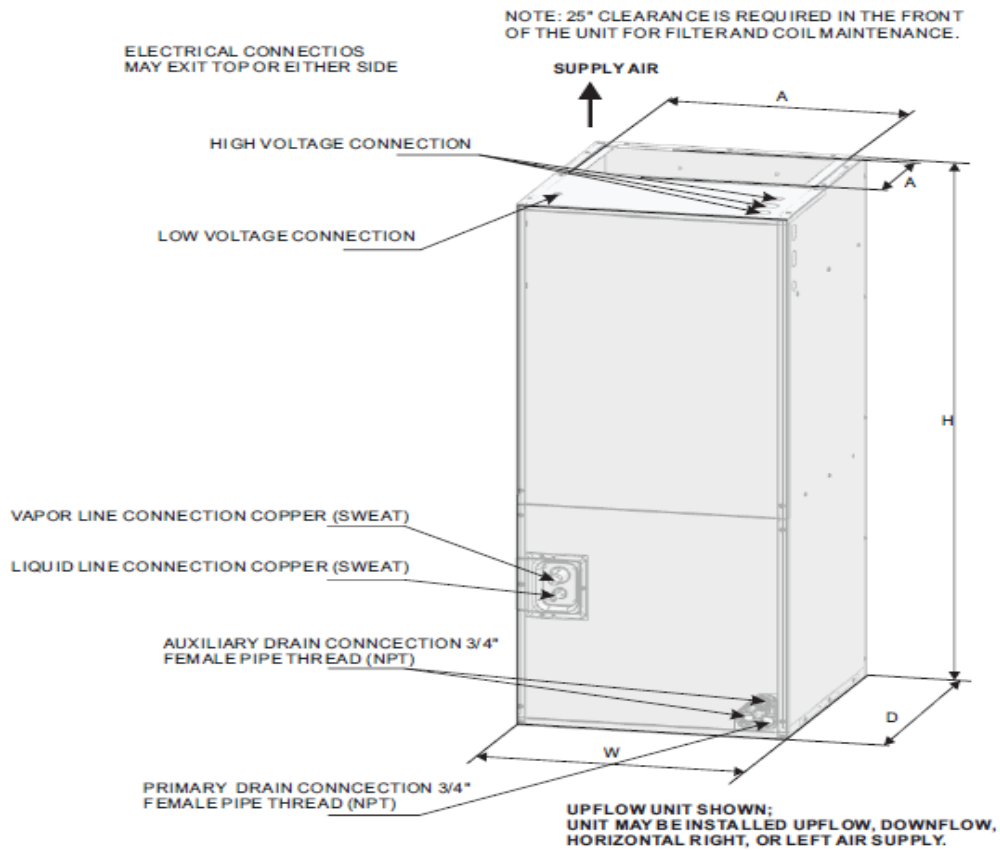

Zero 24k AHU DIMENSIONS					
DIMENSIONAL DATA					
MODEL SIZE	Dimensions				
	UNIT HEIGHT "H"/in	UNIT WIDTH "W"/in	UNIT LENGTH "D"/in	SUPPLY DUCT "A"/in	LIQUID LINE / VAPOR LINE IN
24K	45.75	19.68	22.05	17.87	3/8" / 3/4"

SHRDZ-24-ZERO | Solar HVAC Model "Z" Residential AHU Clearances

SHR*-Zero AHU Clearances | v 1.00 | 01/28/23

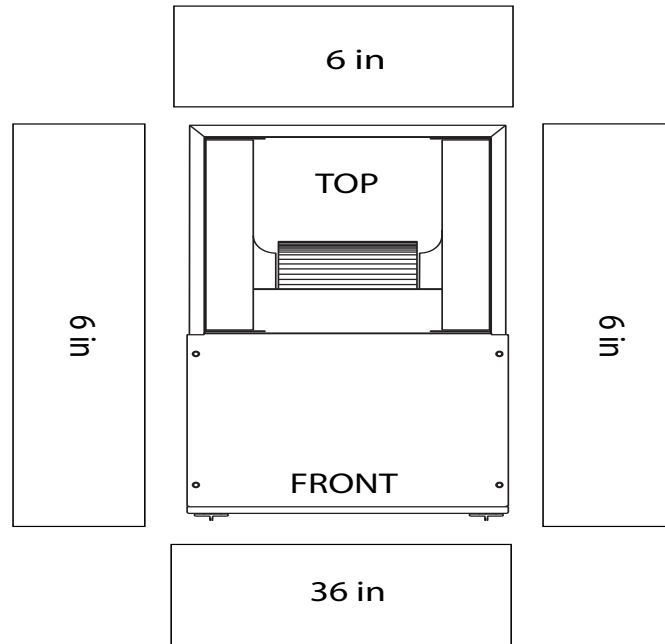

OPTIONAL ELECTRIC HEAT CLEARANCES

