



Solar HVAC 208/230V | Model "D" 3-Ton Condensing Unit

Part Number

SHRDD- 360*00A000 - **

Unit Type

D - Cooling Only

Voltage (*)

G - 230 VAC 1Φ

H - 230 VAC 3Φ

Options (**)

0 - No Options

D - Condenser Coil Coating (UG)

Y - Start Up

7 - Phase Monitor

Description

A Solar HVAC Residential Unit is more than twice as efficient as a standard residential split unit.

A solar box equipped with chambers lined with specialty reflective film is mounted to the top of the condensing unit. Through a patented process, ambient light is converted to thermal energy which reduces the energy demand on the compressor.

Units come with a 1-year parts warranty and 10 year compressor warranty.

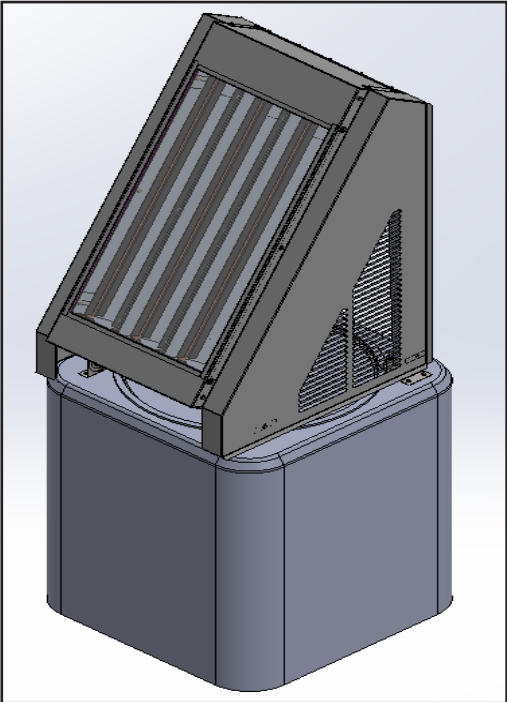



Dimensions

SHRDD-36 | Solar HVAC Model "D" Residential Condenser Dimensions

Model		SHRDD-36 (3 Ton)	
Code	Outdoor Code		
Outdoor Power Supply	V/Hz	208-230V/60Hz	
Cooling	Capacity	Btu/h	35000
		W	2668
	EER	Btu/h, W	11.00
	SEER		13.00
Compressor	Type		Scroll
Outdoor Dimension	Packing (WxHxD)	Inch	32 1/2 x 32 1/2 x 78

(Outdoor Unit) Model		SHRDD-36 (3 Ton)
Outdoor Weight	Net - Lbs (kg)	307 (140)
	*Gross - Lbs (kg)	332 (151)
Electrical Data 208/230 1Φ	Minimum Circuit Ampacity	24.60 A
	Max. Overcurrent Protection	40 A
Electrical Data 208/230 3Φ	Minimum Circuit Ampacity	14.2 A
	Max. Overcurrent Protection	20 A
Outdoor Noise Level (dB(A))		74
Operation Temperatures (°F)		-10 to 115

Note:

Unit should be UL 1995 listed

Unit should be OG-100 Certified to the Solar certification on ICC901/SRCC100

Note: Face solar panels south for optimal performance.

* Gross = Net Weight + Shipping Box

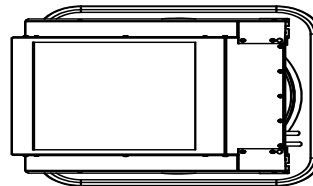
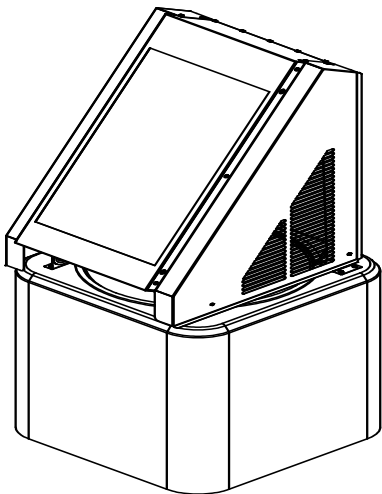
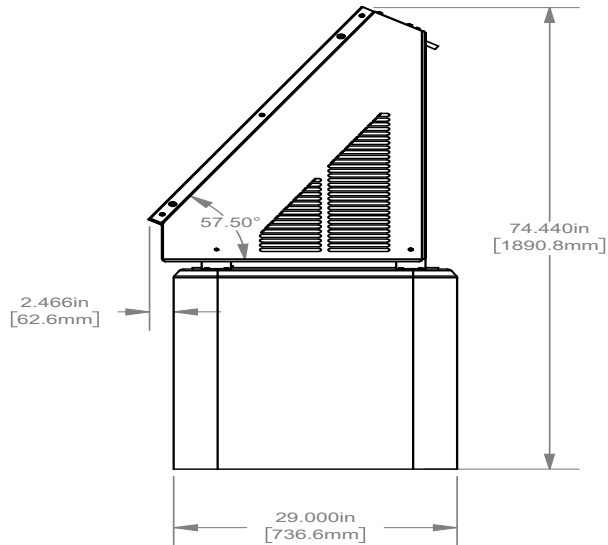
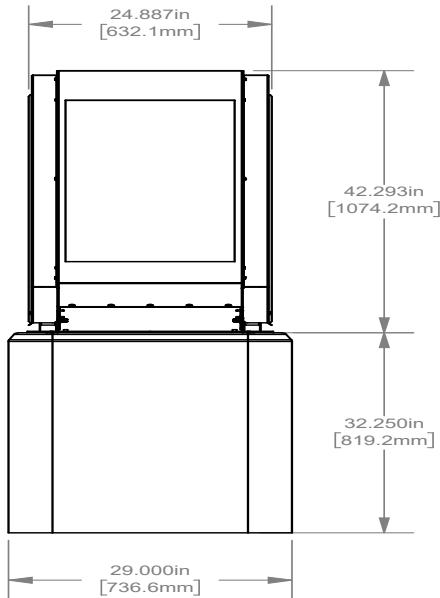

SHRDD-36 | Solar HVAC Model "D" Residential Condenser Clearances

Installation Clearances

Another important consideration in selecting a location for the unit(s) is the angle to obstructions. Either side adjacent the valves can be placed toward the structure provided the side away from the structure maintains minimum service clearance. Corner in-stallations are strongly discouraged.

Special consideration must be given to location of the condensing unit(s) in regard to structures, obstructions, other units, and any/all other factors that may interfere with air circulation. Where possible, the top of the unit should be completely unobstructed; however, if vertical conditions require placement beneath an obstruction there should be a minimum of 60 inches between the top of the unit and the obstruction(s). The specified dimensions meet requirements for air circulation only. Consult all appropriate regulatory codes prior to determining final clearances.

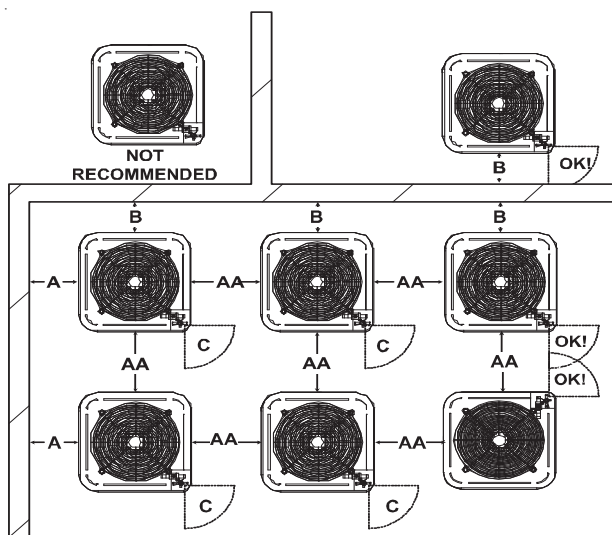

Minimum Airflow Clearance				
Model Type	A	B	C	AA
Residential	10"	10"	18"	20"

This unit can be located at ground floor level or on flat roofs. At ground floor level, the unit must be on a solid, level foundation that will not shift or settle. To reduce the possibility of sound transmission, the foundation slab should not be in contact with or be an integral part of the building foundation. Ensure the foundation is sufficient to support the unit. A concrete slab raised above ground level provides a suitable base.

Rooftop Installations

If it is necessary to install this unit on a roof structure, ensure the roof structure can support the weight and that proper consideration is given to the weather-tight integrity of the roof. Since the unit can vibrate during operation, sound vibration transmission should be considered when installing the unit. Vibration absorbing pads or springs can be installed between the condensing unit legs or frame and the roof mounting assembly to reduce noise vibration.

NOTE: These units require special location consideration in areas of heavy snow accumulation and/or areas with prolonged continuous subfreezing temperatures. Heat pump unit bases have cutouts under the outdoor coil that permit drainage of frost accumulation. Situate the unit to permit free unobstructed drainage of the defrost water and ice.