



Solar HVAC 208/230V | Model "Y" 2.5-Ton Condensing Unit

Part Number

SHRDY- 300*00A000 - **

Unit Type

D - Cooling Only

Voltage (*)

G - 230 VAC 1Φ
H - 230 VAC 3Φ

Options (**)

0 - No Options
D - Condenser Coil Coating (UG)
Y - Start Up
7 - Phase Monitor

Description

A Solar HVAC Residential Unit is more than twice as efficient as a standard residential split unit.

A solar box equipped with chambers lined with specialty reflective film is mounted to the top of the condensing unit. Through a patented process, ambient light is converted to thermal energy which reduces the energy demand on the compressor.

Units come with a 1-year parts warranty and 10 year compressor warranty.

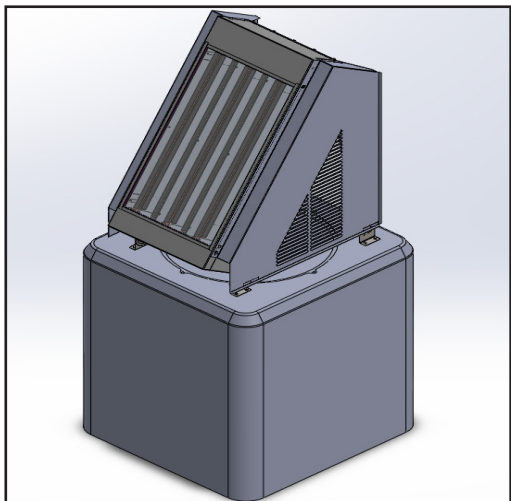



Dimensions

SHRDY-30 | Solar HVAC Model "Y" Residential Condenser Dimensions

Model		SHRDY-30 (2.5 Ton)	
Code	Outdoor Code		
Outdoor Power Supply		V/Hz	208-230V/60Hz
Cooling	Capacity	Btu/h	30000
		W	2500
	EER	Btu/h, W	12
SEER			14
Compressor	Type		Scroll
Outdoor Dimension	Packing (WxHxD)	Inch	38 3/4 x 35 1/4 x 85 1/4

(Outdoor Unit) Model		SHRDY-30 (2.5 Ton)	
Outdoor Weight	Net - Lbs (kg)	251 (114)	
	*Gross - Lbs (kg)	276 (125)	
Electrical Data 208/230 1φ	Minimum Circuit Ampacity	21.51A	
	Max. Overcurrent Protection	35A	
Electrical Data 208/230 3φ	Minimum Circuit Ampacity	12.42A	
	Max. Overcurrent Protection	20A	
Outdoor Noise Level (dB(A))		73.5A	
Operation Temperatures (°F)		-10 to 125	

Note:

Unit should be UL 1995 listed

Unit should be OG-100 Certified to the Solar certification on ICC901/SRCC100

Note: Face solar panels south for optimal performance.

* Gross = Net Weight + Shipping Box

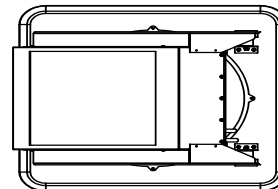
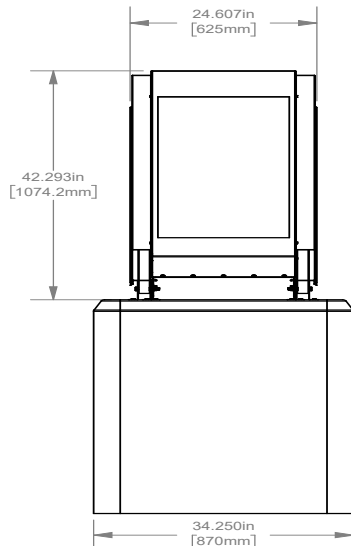
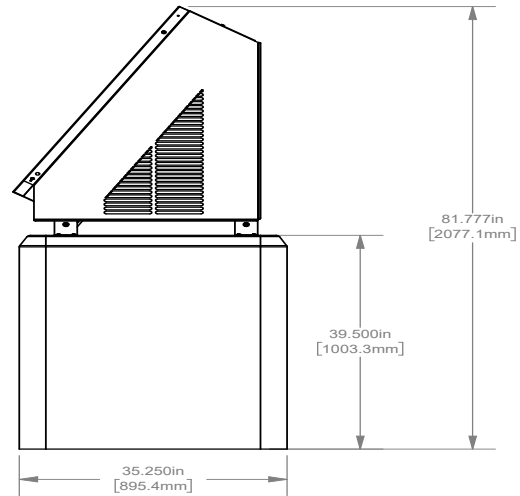
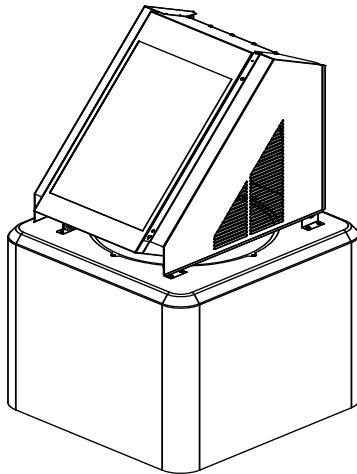

SHRDY-30 | Solar HVAC Model "Y" Residential Condenser Clearances

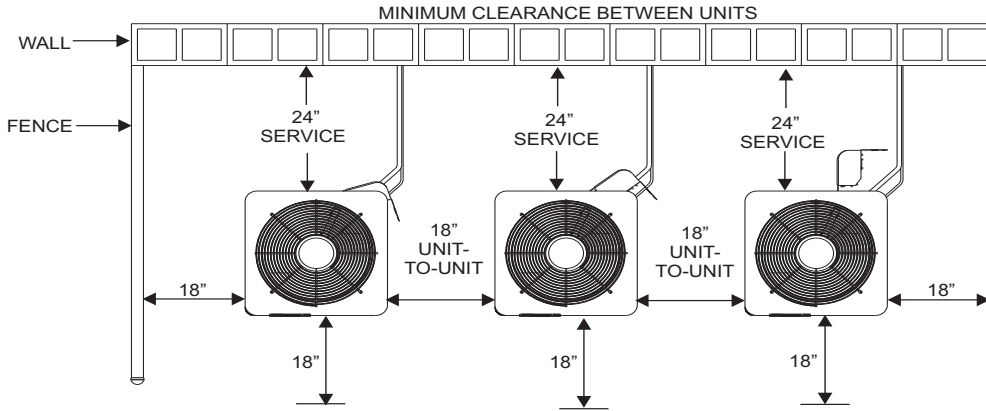

NOTE:
 Clearance between two units may be reduced to 18" minimum provided the service access clearance is increased to 24" minimum, and the clearance on each remaining side is maintained at 18" minimum.

NOTE:
 Clearance to one side of the unit may be reduced to 6" provided the clearance to each remaining side is increased to 12" minimum, the service access is increased to 24" minimum, and the clearances between any two units is maintained at 24" minimum.

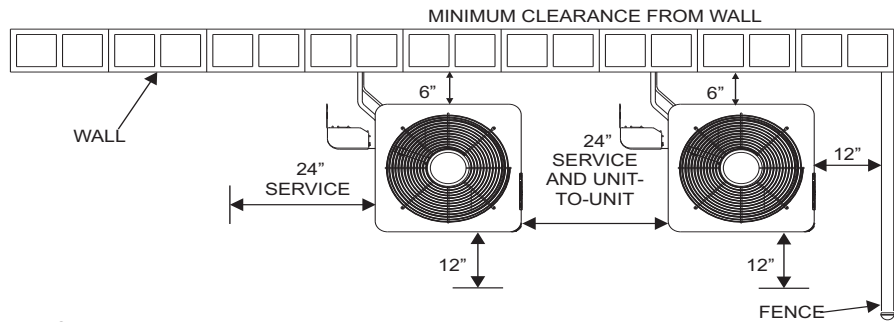

CAUTION:
 Special care must be taken to avoid recirculation of discharge air through condenser coil.