



**TRANE PREC810  
HORIZONTAL  
ECONOMIZERS  
I/O/M MANUAL**

## Table of Contents

Trane Economizer Description.....	3
PREC810 Horizontal Submittal.....	4
PREC810 Horizontal Install.....	5
Additional Install Notes.....	7

**For information on iAIRE's Economizer Controls Package,  
please refer to IOM-0014**

## Trane Economizer Description

**PLEASE NOTE:** Our economizer is a low leak, field installed economizer with the iAIRE patented controls packages and actuator, allowing you to reduce the amount of outside air needed from your rooftop HVAC system by up to 2/3 and will improve indoor air quality.

This reduction in system operation creates on-going utility savings. Payback on capital equipment costs with an iAIRE economizer can be realized in fewer than three years. These packages are designed to work directly on existing rooftop HVAC systems.

These economizers are all low leak and meet the IECC 2015 requirement and are Title 24 compliant by meeting section 120.2(i) for the required controls and the efficiency requirements in 140.4(e).

### Unit to RTU Conversion

PREC810	THC 120G, THC 120H, YHC 120G, YHC 120H, YZC 120E, 120F, WSC 120E, WHC 120H, GERE 120
---------	--

### Part Number

**EC - 1 - 2 3 4 5 - 6**

type	unit/ton (1)							
EC - ECONOMIZER	26 712 1525 3050	6075 100 125 150	CHAS12 CHAS34 CHAS5 CHAS69	A-BOX B-BOX C-BOX D-BOX E-BOX F-BOX Lennox	FND35 PACK13 PREC35 PREC48 PREC610	PREC810 VOY12 VOY12HE VOY1525HE	AFF LXS LXL SCS12 SCS34 SCSHE12 SCSHE34 SCL12	SCL34 SCLHE12 SCLHE34 PRED PREDS SL SLL SLU
	Controls Only		Carrier		Trane			York

### configuration (2)

0 - NO ECON  
C - CONVERTIBLE  
H - HORIZONTAL  
V - VERTICAL

### actuator (3)

0 - NO ACTUATOR  
A - 20 IN-LB  
B - 62 IN-LB  
C - 160 IN-LB

### controls (4)

0 - ECON ONLY  
A - IAQ  
B - IAQ (NO IONIZATION)  
D - DCV

### power exhaust (5)

0 - NO POWER EXHAUST  
A - 208/230V 1Φ FIXED PE  
B - 208/230V 3Φ FIXED PE  
C - 460V 3Φ FIXED PE

### options (6)

0 - NONE  
B - HUMIDITY  
C - BACNET  
D - BLDG PRESSURE\*  
R - RTU OPEN  
U - ULTRA LOW LEAK

Note: By adding option "D" any powered exhaust will be modulating.

# PREC810 Horizontal Submittal

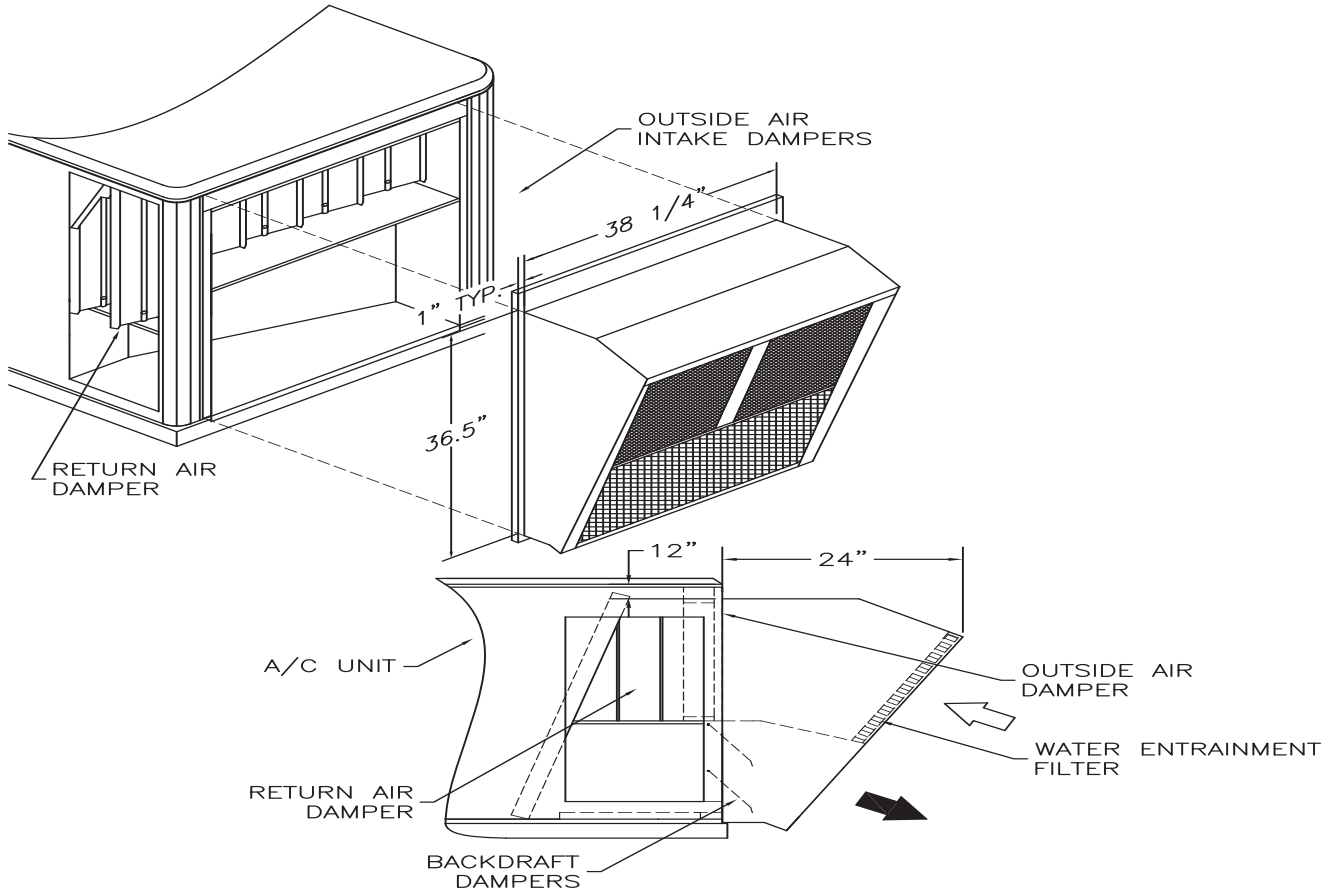

### Electrical Data

PART #	WEIGHT
EC-PREC810-HBA0-*	220 lbs.

PART	AMPS	PART	AMPS	TOTAL
ACTUATOR	.29A	CONTROLS	.27A	.56A

*OPTIONS
0 - No Options
B - Humidity/Enthalpic
C - BACNet

### Features

- **iAIRE Patented Controls Scheme Included**
- Low Leak Damper Included
- VOC, CO2 and Ionization included
- Heavy Gauge Galvanized Steel Construction
- American Sterling Grey Paint Finish
- One Piece Assembly
- Gear Driven Dampers
- Uses HVAC Unit Filter Access Door
- Capable of Relieving up to 100% of the Outside Air Intake

Economizers with Indoor Air Quality control are Title 24 compliant by meeting section 120.2(i) for the required controls and the efficiency requirements in 140.4(e). They also meet California ozone emissions requirements to be CARB certified.

## PREC810 - Horizontal Install

### HORIZONTAL ECONOMIZER INSTALLATION INSTRUCTIONS

- 1 – REMOVE RETURN AIR COMPARTMENT PANEL FROM BACK OF HVAC UNIT.(SEE DETAIL #1)
- 2 – REMOVE SCREWS ON BACK OF HVAC UNIT HOLDING TOP OF HVAC UNIT DOWN. ALSO REMOVE SCREWS ABOUT HALF-WAY DOWN BOTH SIDES OF HVAC UNIT TOP. (SEE DETAIL #1)
- 3 – LIFT TOP OF THE HVAC UNIT AND PROP UP WITH SUPPORTS, 2" SPACING REQUIRED. (SEE DETAIL #2)
- 4 – WHEN USING THE BELIMO ACTUATOR OPTION, CONSULT CONTROLS CONTRACTOR REGARDING THE ECONOMIZER WIRING REQUIREMENTS.
- 5 – SLIDE ECONOMIZER ASSEMBLY INTO THE HVAC UNIT. PUT THE RETURN PORTION INTO THE COMPARTMENT FIRST AND SLIDE TO THE LEFT AGAINST THE HORIZONTAL RETURN OPENING THEN SLIDE THE RIGHT SIDE OF THE ASSEMBLY INTO THE RETURN AIR COMPARTMENT. APPLY GASKET AROUND THE PERIMETER. (SEE DETAIL #2 & #3)
- 6 – SLIDE THE HOOD ASSEMBLY OVER THE DAMPER SECTION. (SEE DETAILS 2 & 3) REMOVE THE SUPPORTS USED TO PROP THE TOP OF THE HVAC UNIT. SUPPORTS USED FROM STEP #3.  
NOTE: THE TOP OF HVAC UNIT HOOKS OVER THE TOP FLANGE OF ECONOMIZER (SEE DETAIL #4)
- 7 – SECURE TOP OF THE ECONOMIZER TO THE HVAC UNIT BY USING SCREWS REMOVED IN STEP #2. ALSO SCREW ALONG THE SIDE FLANGES OF THE ECONOMIZER USING #12 X 1 SCREWS (SEE DETAIL #5)

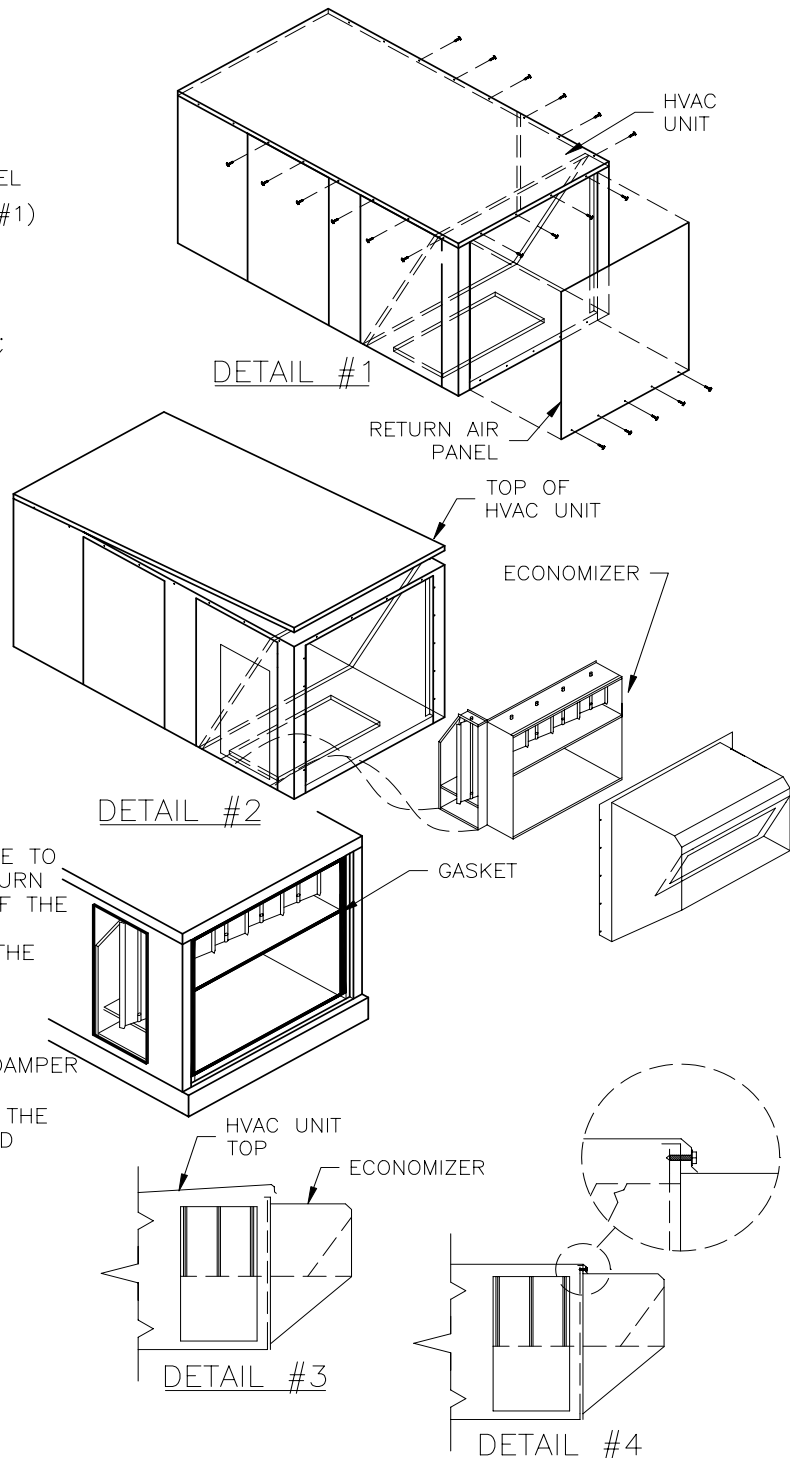

## PREC810 - Horizontal Install (cont'd)

### HORIZONTAL ECONOMIZER INSTALLATION INSTRUCTIONS

- 8 – REPLACE ALL SCREWS ALONG THE SIDES OF THE TOP OF THE HVAC UNIT, REMOVED IN STEP #2. (SEE DETAIL #5)
- 9 – REMOVE RETURN AIR COMPARTMENT PANEL LOCATED ON THE RIGHT OR LEFT SIDE OF HVAC UNIT.  
(SEE DETAIL #6)
- 10 – PLUG ECONOMIZER HARNESS INTO THE HVAC UNIT ECONOMIZER HARNESS.  
NOTE: HARNESS WILL BE INSIDE UPPER CORNER OF RETURN AIR COMPARTMENT.  
(SEE DETAIL #7)
- 11 – REMOVE THE DISCHARGE AIR SENSOR FROM THE SHIPPING LOCATION BEHIND THE WATER ENTRAINMENT FILTER ON THE ECONOMIZER AND MOUNT IT IN THE HVAC UNIT SUPPLY FAN COMPARTMENT NEXT TO THE FAN INLET.

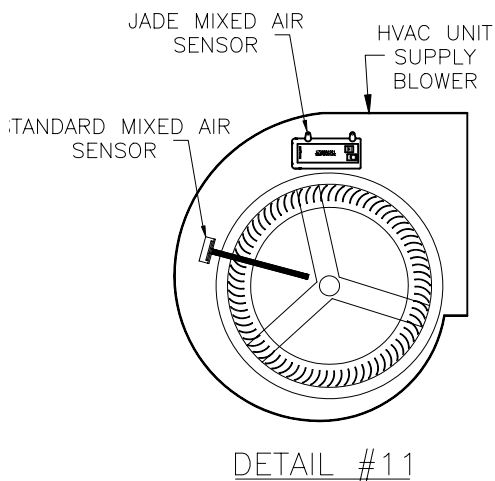
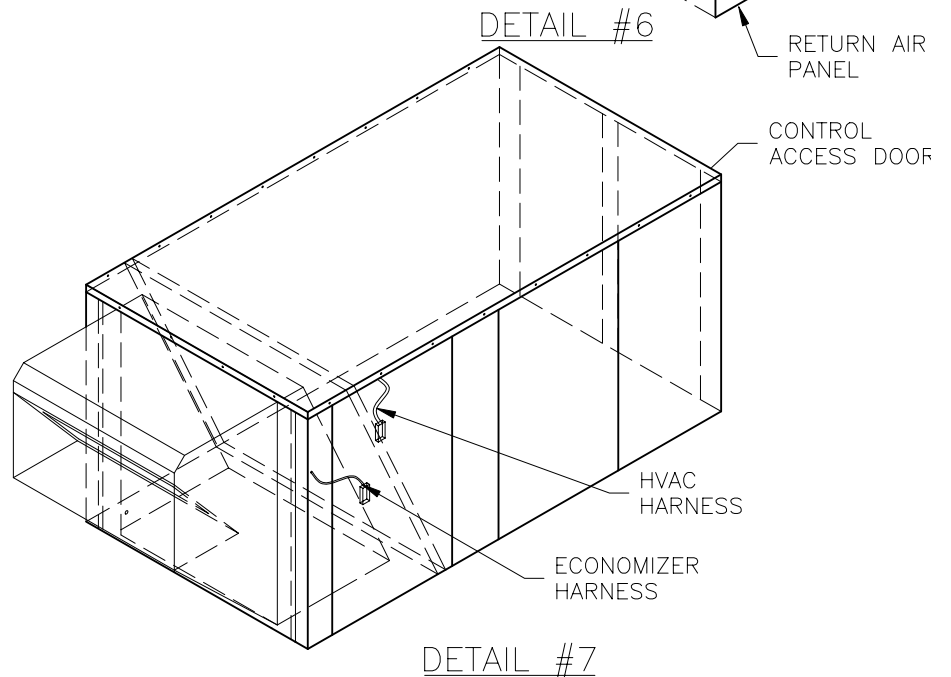
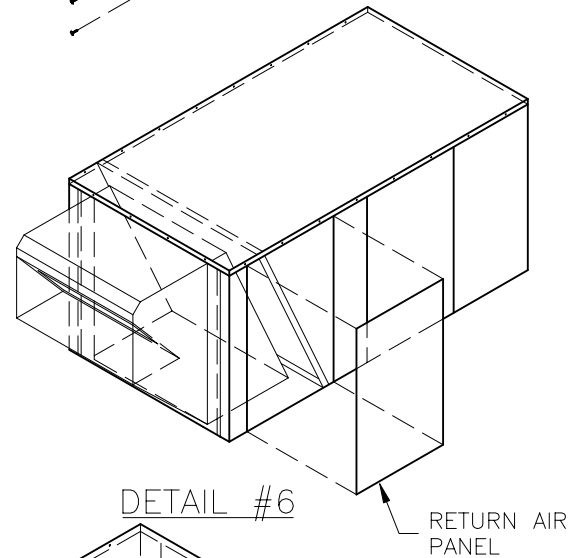
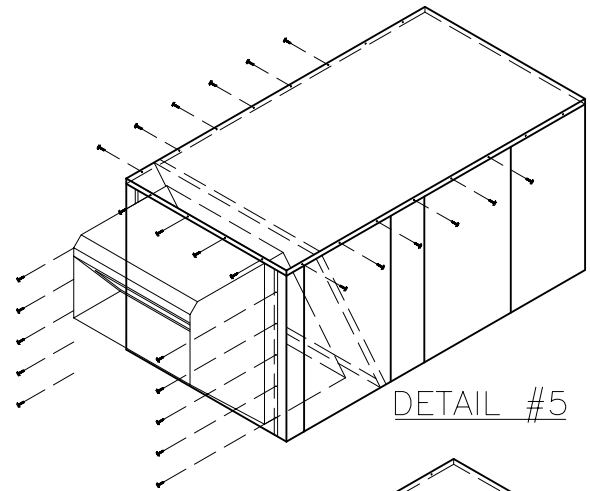

## Trane Economizer Install Notes

### Additional Notes

1. Power Supply. Provide disconnect means and overload protection as required.
2. Motor Spring>Returns closed when unit is not running.
3. Ensure that equipment transformer is sized to handle the extra load of the economizer and actuator.
4. When using a heat with defrost feedback, add an isolation relay between O and C. (Field provided and installed).