



**CARRIER CHAS12  
HORIZONTAL  
ECONOMIZERS  
I/O/M MANUAL**

## Table of Contents

<b>Carrier Economizer Description.....</b>	<b>3</b>
<b>Chassis 1 &amp; Chassis 2 Horizontal Submittal .....</b>	<b>4</b>
<b>Chassis 1 &amp; Chassis 2 Horizontal Install .....</b>	<b>5</b>
<b>Additional Install Notes.....</b>	<b>6</b>

**For information on iAIRE’s Economizer Controls Package,  
please refer to IOM-0014**

## Carrier Economizer Description

**PLEASE NOTE:** Our economizer is a low leak, field installed economizer with the iAIRE patented controls packages and actuator, allowing you to reduce the amount of outside air needed from your rooftop HVAC system by up to 2/3 and will improve indoor air quality.

This reduction in system operation creates on-going utility savings. Payback on capital equipment costs with an iAIRE economizer can be realized in fewer than three years. These packages are designed to work directly on existing rooftop HVAC systems.

These economizers are all low leak and meet the IECC 2015 requirement and are Title 24 compliant by meeting section 120.2(i) for the required controls and the efficiency requirements in 140.4(e).

CHAS to RTU Conversion	
<b>CHAS12</b>	<div style="display: flex; justify-content: space-between;"> <div style="width: 45%;"> <p><b>CHAS1:</b>                      48/50FC 04-05; 50TCQ 04-05;                      48/50GC 04-05, LC 04; 50HCQ 04;                      48/50 TF, TM 004-007; 48TJ 004-007;                      48HJ 004-006; 50TJ 004-006;                      50HJ, HJQ 004-006</p> </div> <div style="width: 45%;"> <p><b>CHAS2:</b>                      48/50TC 07 FC06-07; 50TCQ 06-07;                      48/50GC06, LC 05-06; 50HCQ05-06;                      50HCQ 05-06; 48HJ 007; 50TJ 007</p> </div> </div>

## Part Number

EC - 1 - 2 3 4 5 - 6

type	unit/ton (1)							
EC - ECONOMIZER	26	6075	CHAS12	A-BOX	FND35	PREC810	AFF	SCL34
	712	100	CHAS34	B-BOX	PACK13	VOY12	LXS	SCLHE12
	1525	125	CHAS5	C-BOX	PREC35	VOY12HE	LXL	SCLHE34
	3050	150	CHAS69	D-BOX	PREC48	VOY1525HE	SCS12	PRED
	Controls Only		Carrier	E-BOX	PREC610		SCS34	PREDS
				F-BOX		Trane	SCSHE12	SL
				Lennox			SCSHE34	SLL
							SCL12	SLU
							York	

**configuration (2)**

0 - NO ECON  
 C - CONVERTIBLE  
 H - HORIZONTAL  
 V - VERTICAL

**actuator (3)**

0 - NO ACTUATOR  
 A - 20 IN-LB  
 B - 62 IN-LB  
 C - 160 IN-LB

**controls (4)**

0 - ECON ONLY  
 A - IAQ  
 B - IAQ (NO IONIZATION)  
 D - DCV

**power exhaust (5)**

0 - NO POWER EXHAUST  
 A - 208/230V 1Φ FIXED PE  
 B - 208/230V 3Φ FIXED PE  
 C - 460V 3Φ FIXED PE

**options (6)**

0 - NONE  
 B - HUMIDITY  
 C - BACNET  
 D - BLDG PRESSURE\*  
 R - RTU OPEN  
 U - ULTRA LOW LEAK

Note: By adding option "D" any powered exhaust will be modulating.

# Chassis 1 & Chassis 2 Horizontal Submittal

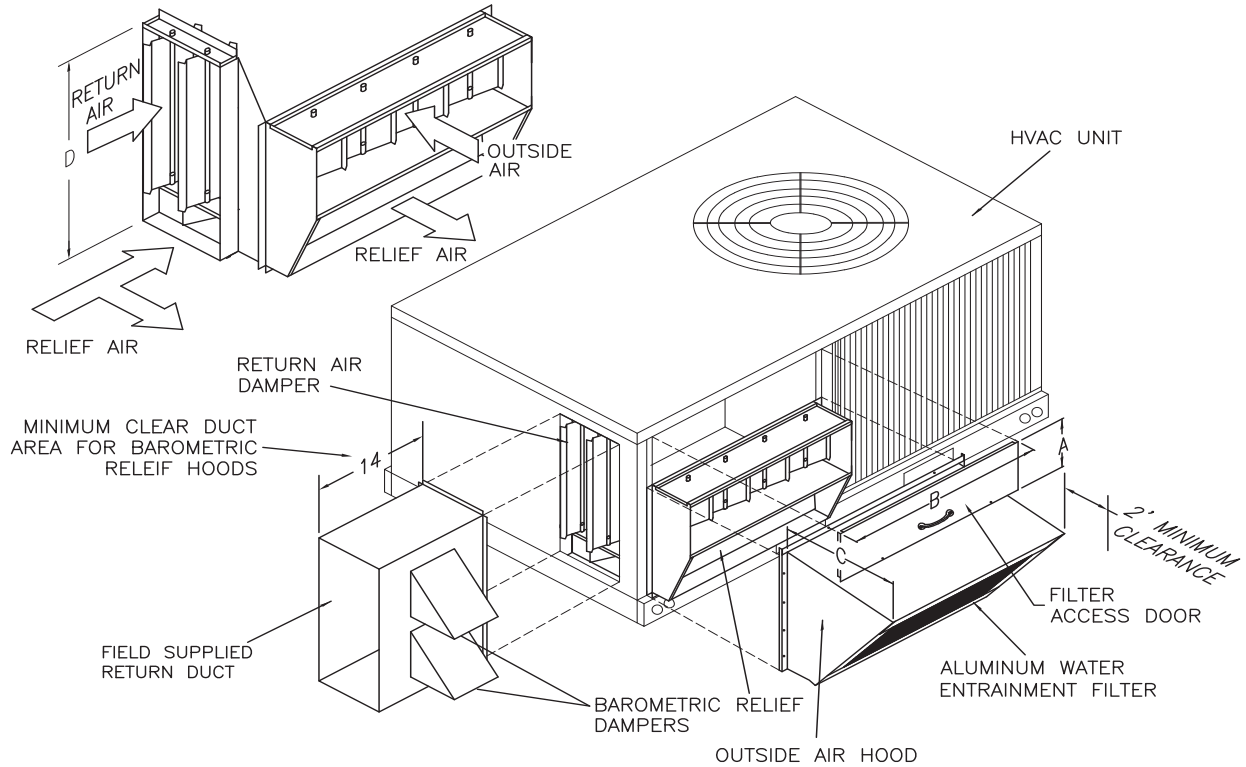

### Dimensions

PART #	A	B	C	D	Relief Hood	Weight
EC-CHAS12-HBA0-*	6.625'	31.5"	18"	25.6875"	2 - 8 x 8	135 lbs.

### EC-CHAS12-HBA0-\*

CFM	SP IN WG
2600	.49
2400	.46
2200	.43
2000	.39
1800	.32
1600	.25
1400	.19
1200	.14
900	.07

### Electrical Data

PART	AMPS	PART	AMPS	TOTAL
ACTUATOR	.29A	CONTROLS	.27A	.56A

*OPTIONS
0 - No Options
B - Humidity/Enthalpic
C - BACNet

### Features

- **iAIRE Patented Controls Scheme Included**
- Low Leak Damper Included
- VOC, CO2 and Ionization included
- Heavy Gauge Galvanized Steel Construction
- American Sterling Grey Paint Finish
- One Piece Assembly
- Gear Driven Dampers
- Uses HVAC Unit Filter Access Door
- Capable of Relieving up to 100% of the Outside Air Intake

Economizers with Indoor Air Quality control are Title 24 compliant by meeting section 120.2(i) for the required controls and the efficiency requirements in 140.4(e). They also meet California ozone emissions requirements to be CARB certified.

## Chassis 1 & Chassis 2 - Horizontal Install

- Carefully remove the economizer from box.
- Remove filter access panel with door from HVAC unit.
- Remove filter(s).
- Slide economizer into unit as shown in figure 1.
  - Note:** EC-CHAS5-H\*\*0-\*, a 12-5/8" x 2-3/4" 18ga blank-off must be screwed over the top splitter of the return air damper frame before sliding in the economizer. Use two 10x1/2" TEK screws.

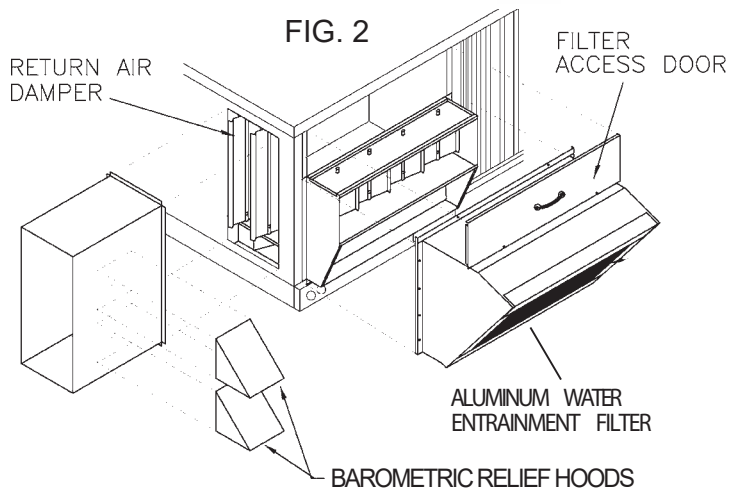
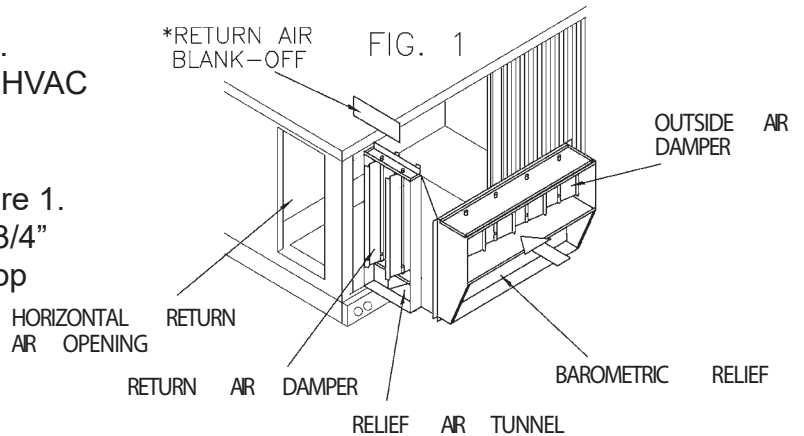

- The return air damper will slide horizontally through the opening and all the way to the left.
- Fasten with screws into the unit.
- Test cycle the economizer and make any necessary adjustment.
- Horizontally install the field supplied duct over the opening. Screw in place and seal.
- Cut openings in the return duct for the two barometric relief hoods. Fasten the hoods to the duct as required. See FIG. 2
  - EC-CHAS12-H\*\*0-\* = QTY (2) 7-3/4" x 7-3/4"
  - EC-CHAS34-H\*\*0-\* = QTY (2) 9-3/4" x 9-3/4"
  - EC-CHAS5-H\*\*0-\* = QTY (2) 11-3/4" x 11-3/4"

- Install the outside air hood over the outside air damper opening. Align the pre-punched holes to the ones on the unit and fasten in place.
- Replace the outside air filter(s) back into the unit.
- Install the filter access door up and under the top of the unit and over the top of the flange of the outside air hood. Fasten. Two filter access doors are supplied to accommodate different unit heights. Discard the unused door. See FIG. 3
- Refer to page 5 in IOM-0014 Economizer Controls Installation Manual for installation of the various sensors and actuators. Connect wires according to the wiring diagram on pg 8.

MODEL	OPENING SIZES
004-007	2-7 3/4" X 7 3/4"
008-014	2-9 3/4"

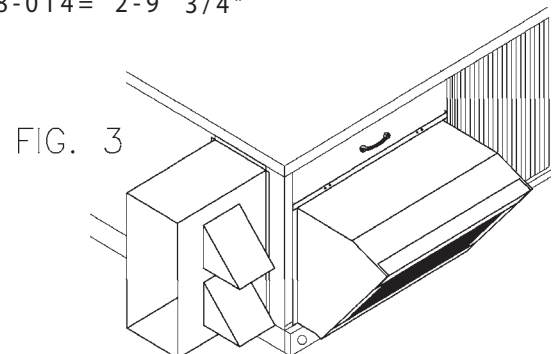

## Carrier Economizer Install Notes

### Additional Notes

1. Motor Spring>Returns closed when unit is not running.
2. Ensure that equipment transformer is sized to handle the extra load of the economizer and actuator.
3. When using a heat with defrost feedback, add an isolation relay between O and C. (Field provided and installed).