

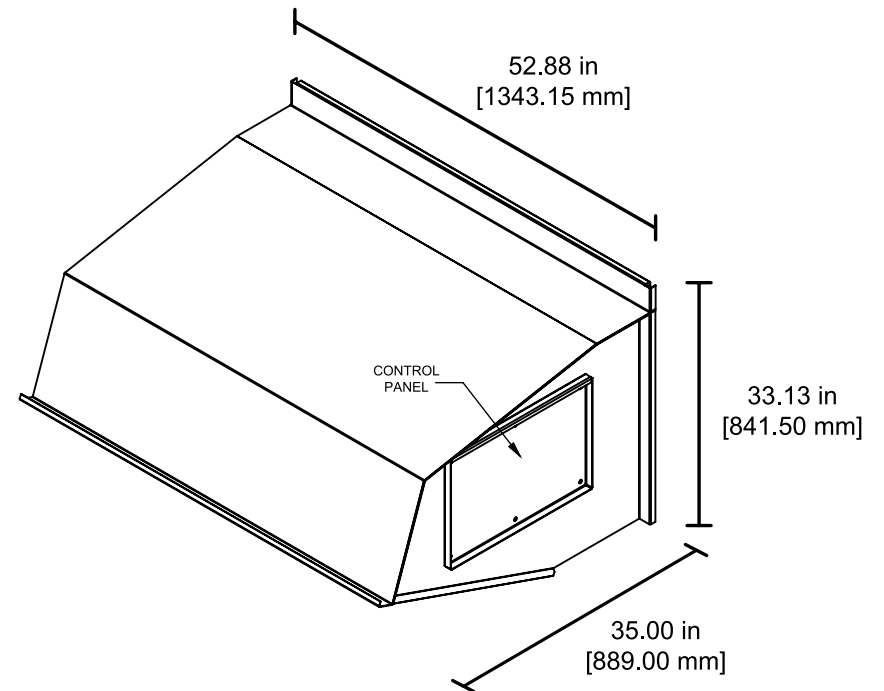

Part Numbers	
AMB * - CHASS5 - * *	
accessory 0 - NO OPTIONS C - MOD DAMPER Z - SPECIAL	options 0 - NO OPTIONS A - BACNET B - MIRROR C - OPTION A & B Z - SPECIAL
package 0 - NO OPTIONS A - IAG B - DCV C - ECON D - CO2 DIRCT CTRL	
Weight	55 lbs [24.9 kg]
Airflow Hood for Carrier Units Listed Below	
Chassis 5 HC14 / TC16 / LC08-09 / LC12	
Power Requirements	
Unit should have 24 VAC power brought in. Power consumption is 9 W.	
Ver. #	1.0.2
Date:	04.11.19

***NOTE:** Powered exhaust can be used with this hood.

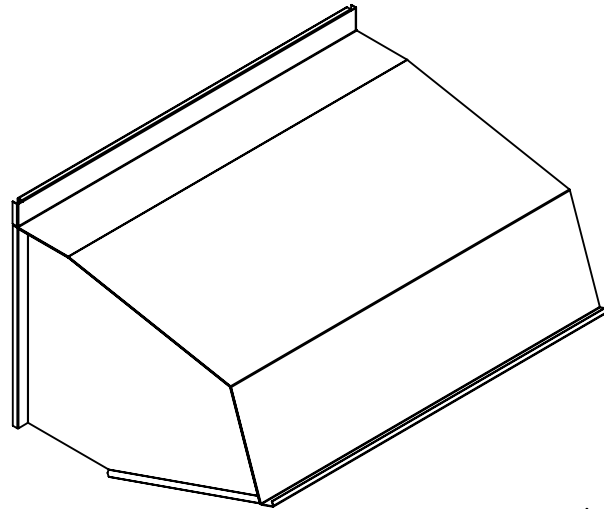

Wiring Diagram

Version 1.1 - 11/27/2013

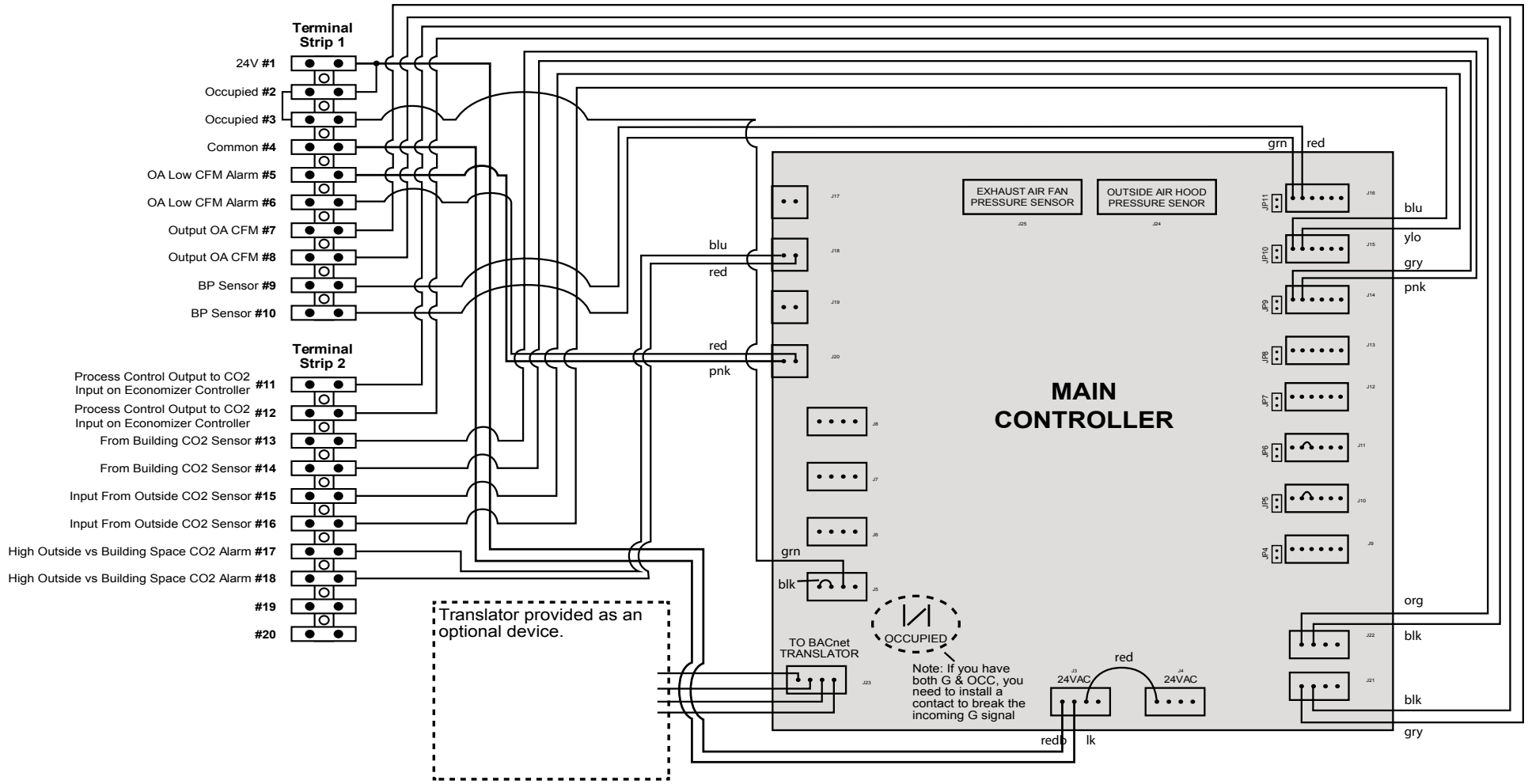

Technical Detail - Terminal Strip & I/O

PIN	NAME	IN / OUT	TYPE
T1-1	24V	INPUT	LINE VOLTAGE
T1-2	OCCUPIED	INPUT	DIGITAL
T1-3	OCCUPIED	INPUT	DIGITAL
T1-4	COMMON	INPUT	LINE VOLTAGE
T1-5	OA LOW CFM ALARM	OUTPUT	DIGITAL
T1-6	OA LOW CFM ALARM	OUTPUT	DIGITAL
T1-7	OUTPUT OA CFM	OUTPUT	ANALOG 0-10V
T1-8	OUTPUT OA CFM	OUTPUT	ANALOG 0-10V
T1-9	BP SENSOR	INPUT	ANALOG 0-10V
T1-10	BP SENSOR	INPUT	ANALOG 0-10V
T2-11	PROCESS CONTROL OUTPUT TO CO2 INPUT ON ECONOMIZER CONTROLLER	OUTPUT	ANALOG 0-10V
T2-12	PROCESS CONTROL OUTPUT TO CO2 INPUT ON ECONOMIZER CONTROLLER	OUTPUT	ANALOG 0-10V
T2-13	FROM BUILDING CO2 SENSOR	INPUT	ANALOG 0-10V
T2-14	FROM BUILDING CO2 SENSOR	INPUT	ANALOG 0-10V
T2-15	INPUT FROM OUTSIDE CO2 SENSOR	INPUT	ANALOG 0-10V
T2-16	INPUT FROM OUTSIDE CO2 SENSOR	INPUT	ANALOG 0-10V
T2-17	HIGH OUTSIDE VS BUILDING SPACE CO2 ALARM	OUTPUT	DRY CONTACT
T2-18	HIGH OUTSIDE VS BUILDING SPACE CO2 ALARM	OUTPUT	DRY CONTACT
T2-19	NOT USED	N/A	N/A
T2-20	NOT USED	N/A	N/A

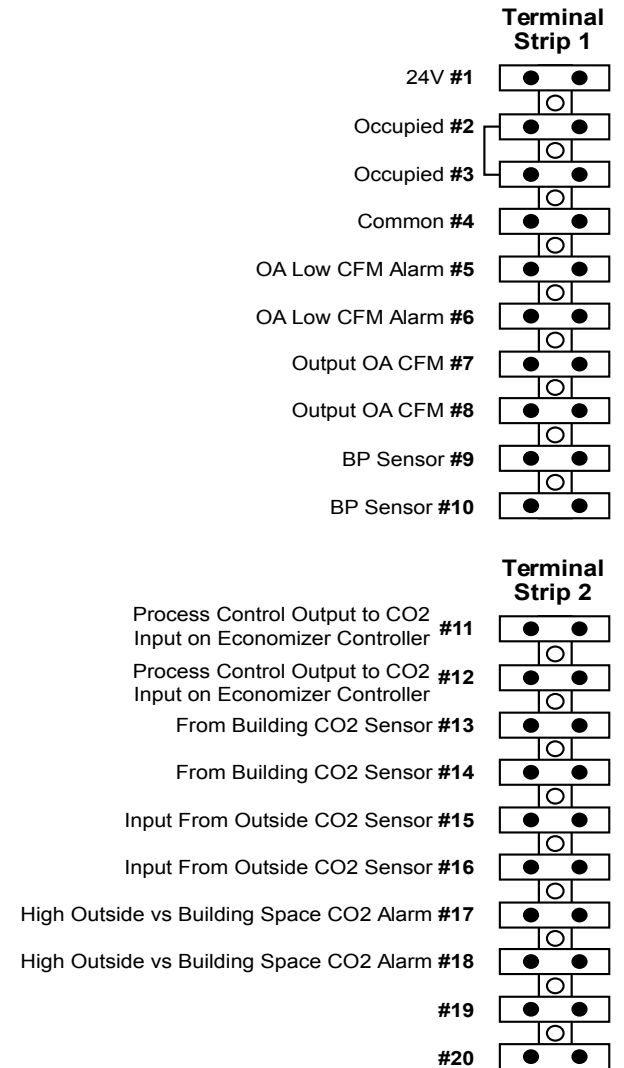

* Any 0-10V signal can be modified to be a 4-20 mA signal. See instructions for how to make this modification.