

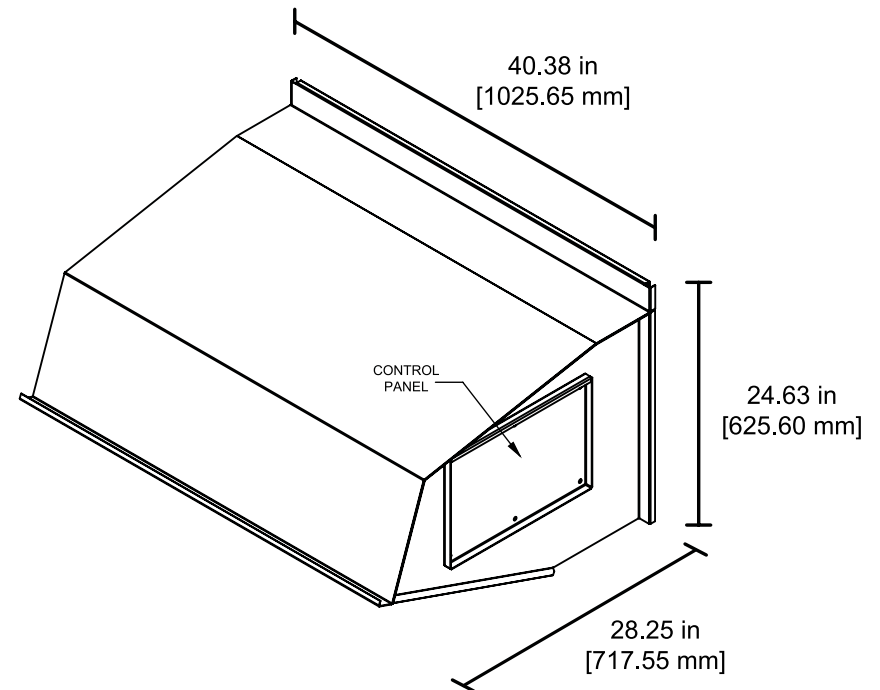

Part Numbers	
<b>AMB * - CHAS4 - * *</b>	
<b>accessory</b> 0 - NO OPTIONS C - MOD DAMPER Z - SPECIAL	<b>options</b> 0 - NO OPTIONS A - BACNET B - MIRROR C - OPTION A & B Z - SPECIAL
<b>package</b> 0 - NO OPTIONS A - IAQ B - DCV C - ECON D - CO2 DIRCT CTRL	
<b>Weight</b>	50 lbs [22.7 kg]
<b>Airflow Hood for Carrier Units Listed Below</b>	
<b>Chassis 4</b> HC08-09 / HC11-12 / TC09 / TC12 TC14 / LC07	
<b>Power Requirements</b>	
Unit should have 24 VAC power brought in. Power consumption is 9 W.	
<b>Ver. #</b>	<b>1.0.2</b>
<b>Date:</b>	<b>04.11.19</b>

**\*NOTE:** Powered exhaust can be used with this hood.

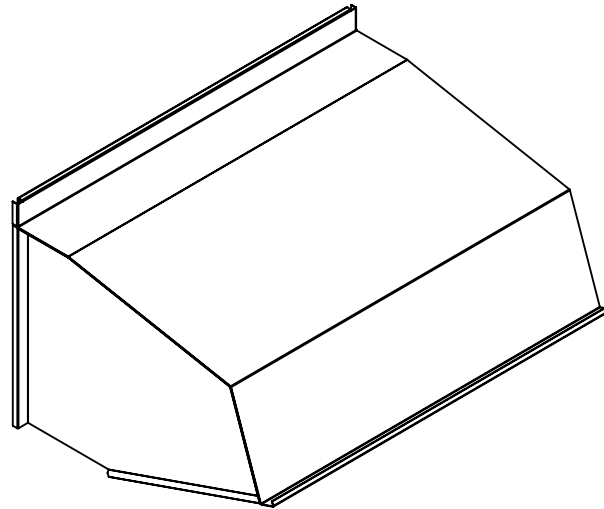

Wiring Diagram

Version 1.1 - 11/27/2013

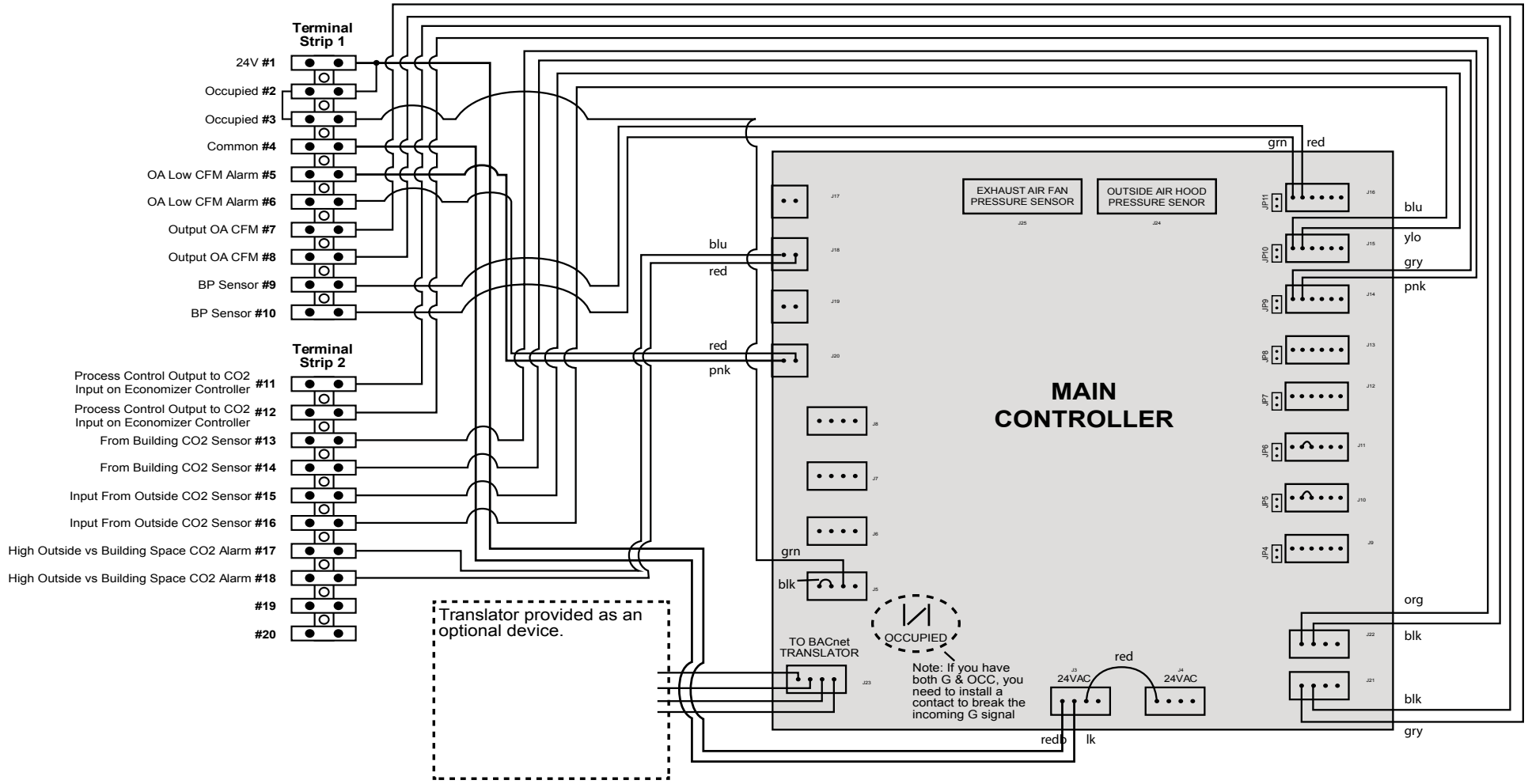

Technical Detail - Terminal Strip & I/O

PIN	NAME	IN / OUT	TYPE
T1-1	24V	INPUT	LINE VOLTAGE
T1-2	OCCUPIED	INPUT	DIGITAL
T1-3	OCCUPIED	INPUT	DIGITAL
T1-4	COMMON	INPUT	LINE VOLTAGE
T1-5	OA LOW CFM ALARM	OUTPUT	DIGITAL
T1-6	OA LOW CFM ALARM	OUTPUT	DIGITAL
T1-7	OUTPUT OA CFM	OUTPUT	ANALOG 0-10V
T1-8	OUTPUT OA CFM	OUTPUT	ANALOG 0-10V
T1-9	BP SENSOR	INPUT	ANALOG 0-10V
T1-10	BP SENSOR	INPUT	ANALOG 0-10V
T2-11	PROCESS CONTROL OUTPUT TO CO2 INPUT ON ECONOMIZER CONTROLLER	OUTPUT	ANALOG 0-10V
T2-12	PROCESS CONTROL OUTPUT TO CO2 INPUT ON ECONOMIZER CONTROLLER	OUTPUT	ANALOG 0-10V
T2-13	FROM BUILDING CO2 SENSOR	INPUT	ANALOG 0-10V
T2-14	FROM BUILDING CO2 SENSOR	INPUT	ANALOG 0-10V
T2-15	INPUT FROM OUTSIDE CO2 SENSOR	INPUT	ANALOG 0-10V
T2-16	INPUT FROM OUTSIDE CO2 SENSOR	INPUT	ANALOG 0-10V
T2-17	HIGH OUTSIDE VS BUILDING SPACE CO2 ALARM	OUTPUT	DRY CONTACT
T2-18	HIGH OUTSIDE VS BUILDING SPACE CO2 ALARM	OUTPUT	DRY CONTACT
T2-19	NOT USED	N/A	N/A
T2-20	NOT USED	N/A	N/A

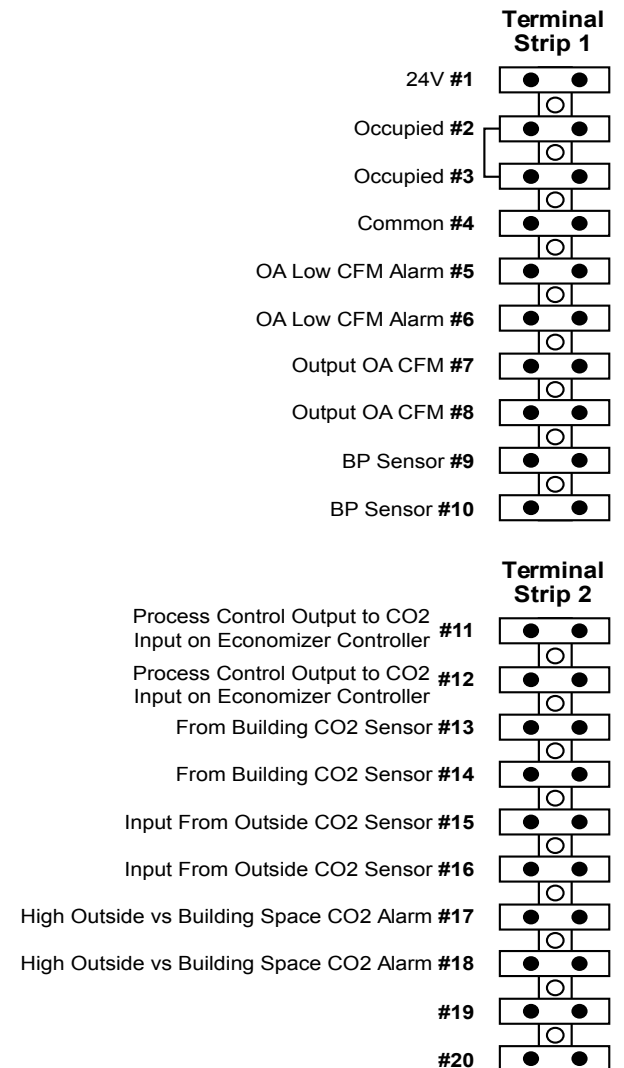

\* Any 0-10V signal can be modified to be a 4-20 mA signal. See instructions for how to make this modification.