

READ THESE INSTRUCTIONS BEFORE YOU BEGIN INSTALLATION

INTRODUCTION

The Duct Particulate Matter Sensor uses an optical sensor based on laser scattering principles and features innovative contamination resistance technology to perform highly accurate and reliable PM measurements. With a continuous-operation lifetime of more than 8 years, the sensor will provide long-term reliability and high-resolution particle size binning for the detection of environmental dust and other particles.

The sensor achieves excellent performance characteristics, including high accuracy and low power consumption to ensure stable long-term operation. The duct particulate sensor features both 4-20 mA and voltage outputs (0-5 / 0-10 Vdc) for simple integration into any building automation system to assure good air quality. The device comes with an RS-485 MS/TP network connection with BACnet® protocol.

BEFORE INSTALLATION

Read these installation instructions carefully before commissioning the sensor. Failure to follow these instructions may result in product damage. Do not use in an explosive or hazardous environment, with combustible or flammable gases, as safety or emergency stop devices or in any other application where failure of the product could result in personal injury. Use electrostatic discharge precautions during installation and do not exceed the device ratings.

INSTALLATION

The duct type sensor installs on the outside of a return air duct with the sampling tube inserted into the duct. **IMPORTANT:** The duct PM sensor must be mounted in relation to the airflow. Use the AIRFLOW directional arrow on the enclosure cover to determine the correct orientation. Incorrect readings will occur if not mounted correctly. See Figure 1.

Mount the sensor in an easily accessible location in a straight section of duct at least five feet from corners or other items that may cause disturbances in the air flow. Avoid areas where the detector is exposed to vibrations or rapid temperature changes.

The principal of operation is based on the Venturi effect of the probe that extends into the HVAC duct. Air flowing through the duct is forced into the vent holes on one side of the probe, into the enclosure, through the PM sensor and then the air is drawn back out of the enclosure via the vent holes on the opposite side of the probe.

Drill or punch a 7/8" or 1" hole in the duct at the preferred location and insert the probe into the hole to mark the enclosure mounting holes. Remove the unit and drill the two mounting holes.



Figure 1

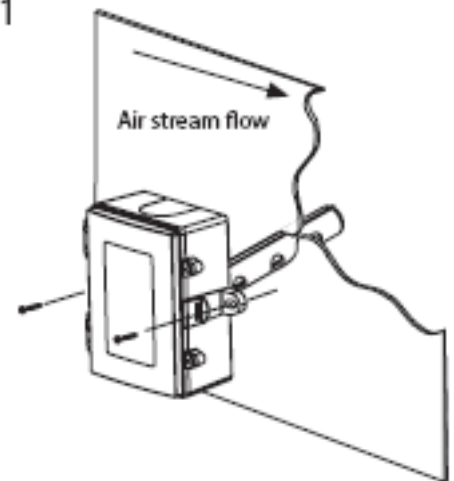

Clean all drilled holes of debris before mounting the device. Mount the enclosure to the duct with two sheet metal screws such that the duct air flow is parallel with the vent holes in the probe (i.e.: air flows directly into the probe holes). To prevent air leaks, ensure the gasket is compressed around the probe between the device enclosure and the air duct. See Figure 1.

The enclosure has a hinged cover with a latch. Open the cover by pulling slightly on the latch on the bottom of the enclosure, at the same time pulling on the cover. See Figure 2. A 1/2" NPT threaded connection hole is provided in the bottom of the enclosure. Screw an EMT connector or cable gland connector in until tight. A weatherproof conduit or cable gland fitting is recommended. There is an optional 1/2" NPT to M16 thread adapter and cable gland fitting. See Figure 3.

Figure 2

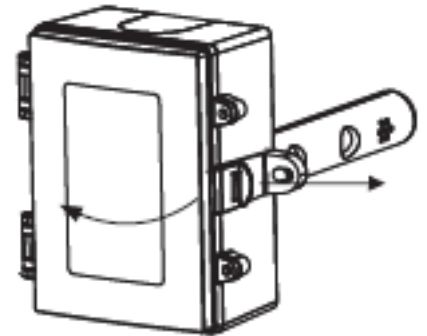
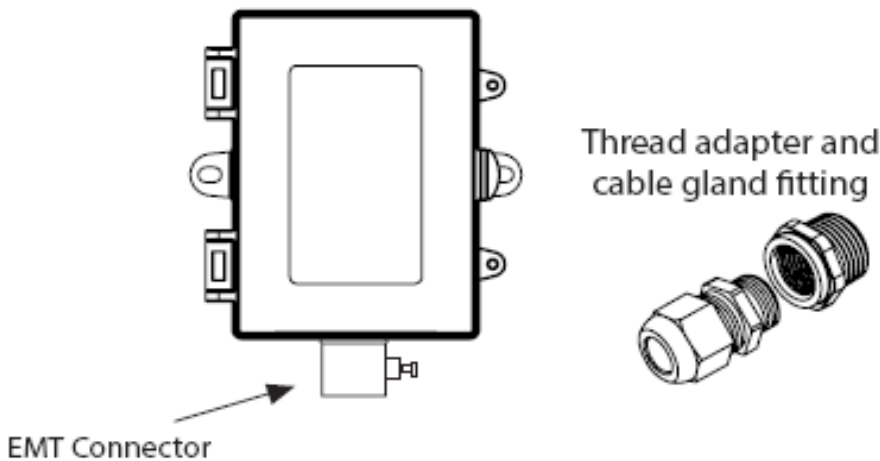
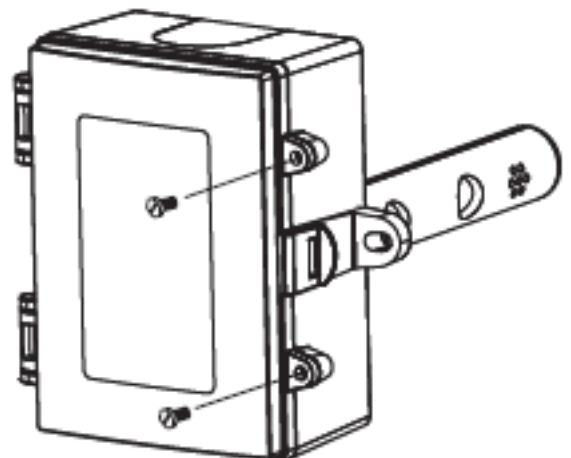

Figure 3



Two security screws are provided which can be installed to help secure the cover once settings and wiring connections are complete. See Figure 4.

Figure 4



WIRING

The sensor has standard screw block connectors and easy wire access to facilitate wiring. It is recommended that shielded twisted pair wiring at least 22 AWG be used for all connections and that the device wires not be run in the same conduit with wiring used to supply inductive loads such as motors. Disconnect the power supply before making any connections to prevent electrical shock or equipment damage. Make all connections in accordance with national and local electrical codes.

The device should be connected to a 24Vac/dc, class 2 power supply. The PWR terminal is used for the positive DC voltage or the hot side of the AC voltage. The device is reverse voltage protected and as such will not operate if connected backwards.

The common of the power supply is connected to the terminal marked COM. Note that this device has

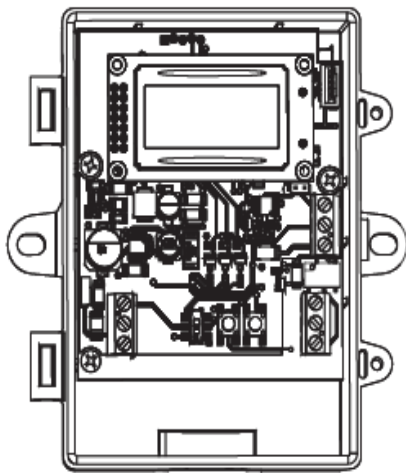

a half-wave type power supply which means the power supply common is the same as the output signal common. Therefore, several devices may be connected to one power supply and the output signals all share the same signal common. Use caution when grounding the secondary of an ac transformer or when wiring multiple devices to ensure that the circuit ground point is the same on all devices and the controller. In general, the transformer should not be connected to earth ground when using devices with an RS-485 network connection.

The analog output signal is available on the OUT terminal. This signal is switch selectable for either voltage or 4-20 mA output signal type. See Figure 6. The voltage output signal defaults to 0-5 Vdc but may be changed to 0-10 Vdc via the menu. These

options are clearly indicated on the device PCB. The analog output signal is typically connected directly to the Building Automation System (B.A.S.) and used as a control parameter or for logging purposes. Check the controller Analog Input type to determine the correct connection and signal type before applying power. The device generates the analog output signal (sourcing) and must not be connected to a powered input or device damage may occur.

Figure 6

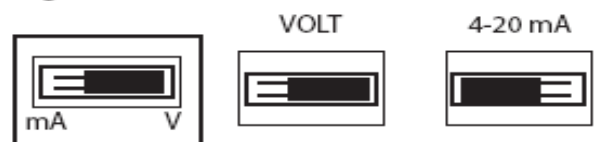

For voltage type output signal the device has a minimum load that it is able to drive, similarly for

Figure 7

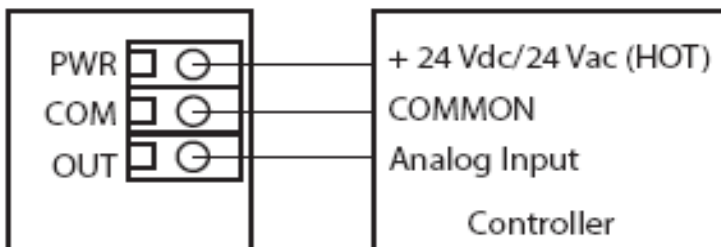

current type output signal the device has a maximum load that it is able to drive with a particular power supply voltage. Observe and follow these ratings in the Specification section or inaccurate reading may result. The 4-20 mA output signal can easily be converted to a 1-5 Vdc signal for controllers accepting this type of input. Simply insert a 250 ohm (0.1% is best) resistor between the “+” and “-” inputs of the

controller. This will convert the 4-20 mA signal to the desired 1-5 Vdc. See Figure 7.

Since the device includes the network connection, use twisted shielded pair to connect to the terminals marked A-, B+ and SH (SHIELD).

The positive wire connects to B+, the negative to A- and the cable shield must be connected to the SH terminal on each device. The shield wire should be connected to earth ground at one end of the network only. If the device is installed at either end of an RS-485 network, an end-of-line (EOL) termination resistor (121 Ω) should be installed in parallel with the A- and B+ terminals. See Figure 8.

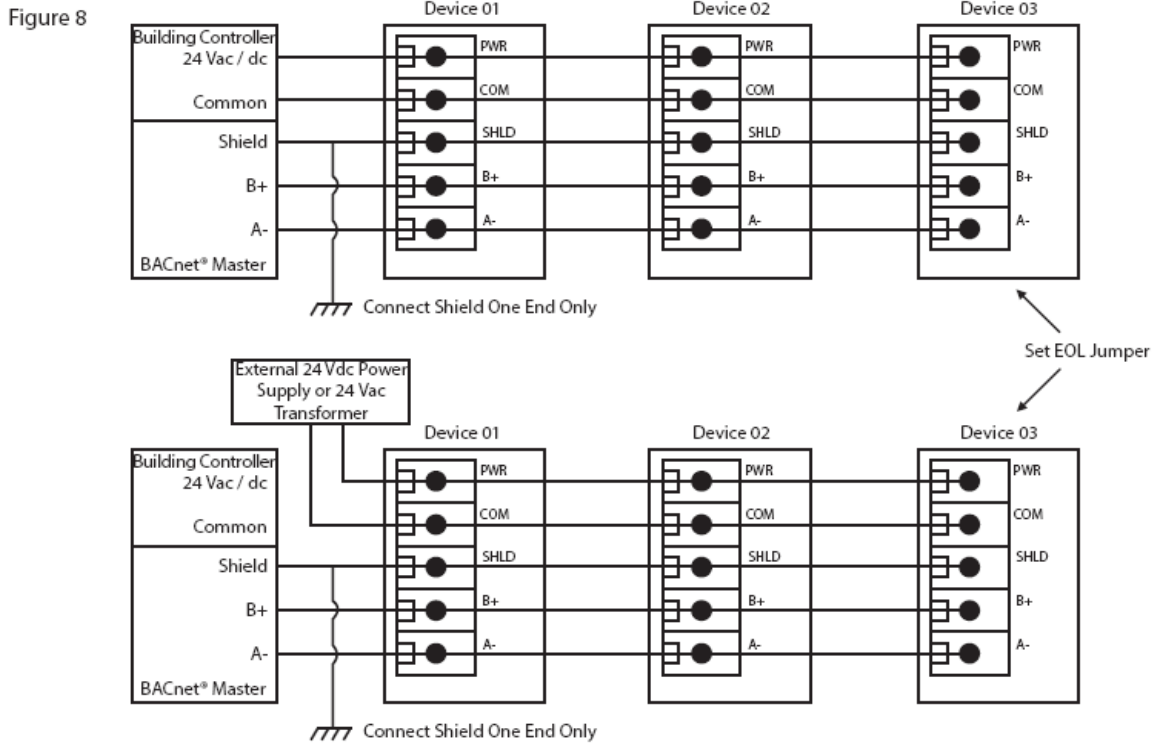

This device includes a network termination resistor and jumper that can be used to connect the EOL resistor on the PCB. Simply move the jumper to the EOL position and no external resistor is required. See Figure 9.



OPERATION - START-UP

After applying power to the device, it will enter the start-up mode and the LCD will indicate the software version number, the PM range, the PM alarm setpoint and the analog output type for two seconds each.



Then the start-up sequence will show the network protocol, the baud rate and the device address. Then the device will start normal operation and display the PM concentration value.



OPERATION - NORMAL

During normal mode the device reads the PM sensor and calculates the Air Quality Index based on a 24 hour time average. The real time PM concentration value is displayed on the LCD and set as the output value for the analog output. The output value is updated once per second. The LCD may be configured via the menu to display either the PM value or the AQI. The tri-color LED will change color to indicate Good (Green), Moderate (Yellow) or Poor (Red) air quality.

On start-up when the first readings are obtained, the Air Quality reading for the device averages the concentration level as necessary until the required time base setting is reached. For example, if only 10 readings are available then the output value is calculated as the average of those 10 readings. The next output value will be an average of 11 readings. This short-averaging will continue until the unit has been running for 24 hours. Once 24 hours is reached then the AQI value will always be the average of readings over the past 24 hours.

The device also monitors the keypad and takes appropriate menu actions for setup. The product allows for configuration of settings via BACnet® protocol and the BACnet® objects are updated with the appropriate values and alarm conditions are monitored.

OPERATION - ALARM

The alarm will control the network variables as applicable to the model. The PM alarm setpoint, hysteresis and time delay may be configured via the menu or network. The details of each setting and operation is explained in the Setup Menu section.

OPERATION - SETUP MENU

The Setup Menu has several items as shown below. To enter the menu, press and release the <MENU> key while in normal operation. This will enter the Setup Menu step 1, pressing the <MENU> key a second time advances to step 2. Each press of the <MENU> key saves the selection and advances the menu item. The <ROLL> key is used to make changes to program variables by

scrolling through the available options. If the Setup Menu is not active for 5 minutes (no key press), then the menu will exit and the device returns to normal operation.

<MENU> Press and hold to enter the setup menu. Once in menu release **<MENU>**.

1: Particulate Matter Range

*PM Range
PM10*

The default PM Range is PM10. Use **<ROLL>** to change the range as required to either PM1.0, PM2.5, PM4.0, or PM10.

<MENU> Press to advance to next menu item

2: Voltage Output Signal

*Output
0-5 Vdc*

Use **<ROLL>** to set the voltage output signal type to 0-5 or 0-10 Vdc. The factory default is 0-5 Vdc.

<MENU> Press to advance to next menu item

3: Analog Output

*Output
Direct*

The analog output defaults to Direct (4-20 mA, 0-5 Vdc or 0-10 Vdc). Use **<ROLL>** to change it to Reverse (20-4 mA, 5-0 Vdc or 10-0 Vdc) if required.

<MENU> Press to advance to next menu item

4: Analog Output Scale

*Scale
1000 ug*

The default analog output scale is 0-1000 ug/m³. The maximum value can be changed from 500 to 1000 (resolution 100) using **<ROLL>** if required. For example, the output can be 4-20 mA = 0-700 ug/m³.

<MENU> Press to advance to next menu item

5: Display Information

*Display
ug/m³*

Use **<ROLL>** to configure the display information as Mass Concentration in ug/m³ or as an Air Quality Index (0-500 AQI / GOOD, MODERATE, POOR). The display will change from ug/m³ to AQI.

<MENU> Press to advance to next menu item

6: Backlight

*Backlite
Auto*

The backlight operation defaults to Auto operation. It can be set to Off or On using **<ROLL>**. Auto means the LCD backlight only lights when a menu is accessed, off means it never lights and on means it is always on.

<MENU> Press to advance to next menu item

7: Setpoint Alarm

*PM Alarm
150 ug*

Setpoint for PM alarm activation. Default setpoint for alarm activation is 150 ug/m³. Use **<ROLL>** to adjust from 50-900 ug/m³. Resolution is 10 ug/m³.

<MENU> Press to advance to next menu item

(Relay or Network Option Continued)

8: Alarm Hysteresis

Alrm Hys
20 ug

The default PM alarm hysteresis is 20 ug/m³. Use <ROLL> to change to 10, 15, 20, 25, 30, 35 or 40 ug/m³. If the PM Alarm setpoint = 150 and hysteresis = 20, then the alarm will be set if the PM exceeds 150 and will reset when it falls below 130.

<MENU> Press to advance to next menu item

9: Alarm Delay

Alrm Dly
0 min

The default PM alarm delay is 0 minutes. Use <ROLL> to change from 0 to 10 minutes to prevent false alarms. Resolution is 1 minute.

<MENU> Press to advance to next menu item

10: PM Alarm

PM Alarm
Test Off

The default PM alarm test is Off. Use <ROLL> to toggle it Off or On. When set to On, an alarm condition is forced for testing purposes. If a relay is installed it will also be activated. The alarm condition will be reset to Off.

<MENU> Press to advance to next menu item

11: BAUD Rate

BaudRate
9600

The default network baud rate is 9600. Use <ROLL> to select 9600, 19200, 38400, 57600, 76800 or 115200 as required.

<MENU> Press to advance to next menu item

12: Address

Address
3

The default network address is 3 for BACnet®. Use <ROLL> to select 0-127 for a BACnet® device.

<MENU> Press to advance to next menu item

DIMENSIONS:

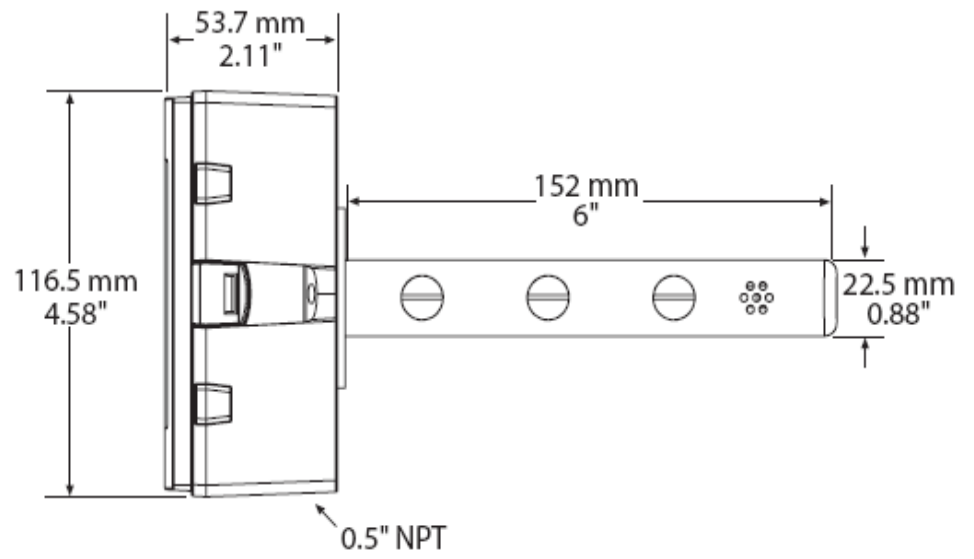
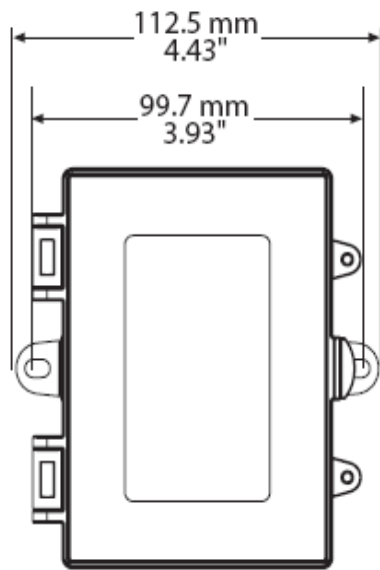

SPECIFICATIONS:

PM Sensor

Sensor.....	Laser scatter method
Particle Size.....	PM1.0, PM2.5, PM4.0, PM10 (selectable)
Mass Concentration.....	0 to 1000 ug/m ³
Resolution.....	1 ug/m ³
Accuracy.....	±10 ug/m ³ (0 to 100 ug/m ³), ±10% (100 to 1000 ug/m ³)
Response Time.....	1 second
Sensor Lifetime.....	>8 years

Analog Model

Consumption.....	75 mA max @ 24 Vdc, 100 mA max @ 24 Vac
Output Signals.....	4-20 mA (sourcing) or 0-5 Vdc / 0-10 Vdc (selectable)
Output Drive Capability.....	Current: 550Ω max
Voltage: 5,000Ω min	
Output Scale.....	0 to 1000 ug/m ³ (menu selectable)

BACnet® Model

Consumption.....	50 mA max @ 24 Vdc, 80 mA max @ 24 Vac
Interface.....	MS/TP, 2-wire RS-485
Baud Rate.....	9600, 19200, 38400, 57600, 76800 or 115200 (menu selectable)
Address Range.....	0 to 127 (menu selectable)

Tri-Color LED

Good.....	Green (0 to 50 ug/m ³)
Moderate.....	Yellow (51 to 150 ug/m ³)
Poor.....	Red (151 to 1000 ug/m ³)

PM Alarm Relay (optional)

Contact Ratings.....	Form C (N.O. + N.C.), 2A @ 140 Vac, 2A @ 30 Vdc
Relay Setpoint + Hysteresis.....	Programmable via menu
Relay Time Delay.....	Programmable via menu

General

LCD Size.....	35mm W x 15mm H (1.4" x 0.6") alpha-numeric 2 line x 8 characters
LCD Backlight.....	Enable or disable via menu
Display Values.....	0 to 500 Air Quality Index or 0 to 1000 ug/m ³
Power Supply.....	Class 2 24 Vac/dc ±20% (non-isolated half-wave rectified)
Protection Circuitry.....	Reverse voltage protected, overvoltage protected
Operating Conditions.....	-10 to 60°C (14 to 140°F), 0 to 95 %RH non-condensing
Storage Conditions.....	-40 to 70°C (-40 to 158°F)
Wiring Connections.....	Screw terminal block (14 to 22 AWG)
Enclosure Dimensions.....	116 mm W x 100 mm H x 54 mm D (4.6" x 3.9" x 2.1")
Enclosure Material.....	Polycarbonate, UL94V-0
Enclosure Protection.....	IP65 (NEMA 4X)
Country of Origin.....	Canada

Accessories

PMFRSM.....	Replaceable sensor module and wire harness
-------------	--